

**YOUR ADVENTURE UNFOLDS**

# K1 Expedition

with built-in coaming

*Feathercraft*  
**FOLDING KAYAKS** <sup>TM</sup>

Feathercraft Products Ltd. 4-1244 Cartwright Street on Granville Island, Vancouver, British Columbia, Canada V6H 3R8  
Telephone: (604) 681-8437 Toll Free: 1-888-681-8437 Fax: (604) 681-7282 [www.Feathercraft.com](http://www.Feathercraft.com) [info@feathercraft.com](mailto:info@feathercraft.com)

# Contents

K1 Expedition Single Folding Kayak .....	Page 2
Specifications .....	Page 3
K1 Expedition Frame .....	Page 4
Care and Maintenance .....	Page 5
K1 Expedition Assembly Instructions .....	Page 7
Disassembly .....	Page 26
The Feathercraft Sea Sock.....	Page 27

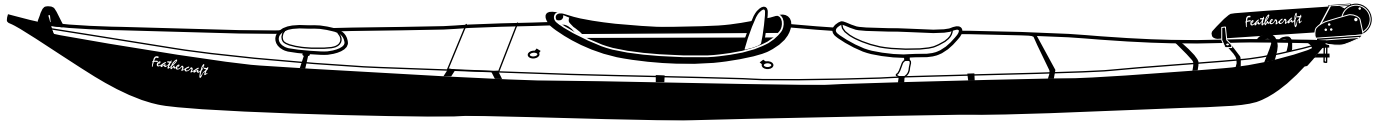

## K1 Expedition Single Folding Kayak

Feathercraft Folding Kayaks are the culmination of many years of design development and testing. The Feathercraft K1 is a high volume, ocean touring kayak that performs well in rough conditions. Due to its modified 'V' cross-section and upswept bow, the kayak tracks well, is stable, responsive and fast. The kayak is easy to assemble and folds into one compact pack-bag.

# Specifications

Length:	5m (16'6")	Seat:	1/2" closed cell foam back & bottom, contoured plastic seat bottom, 3/16" plastic seat back with inflatable lumbar support, inside a 420 denier nylon seat cover.
Beam at Cockpit:	64 cm (25")	Sponsons:	Urethane
Pack size:	92 x 46 x 30 cm (36 x 18 x 12")	Standard Accessories:	Nylon Spray Skirt
Weight:	24 kg (52 lbs)		Sea Sock
Frame:			Adjustable Foot Braces/Rudder Controls
Main Members:	3/4" O.D. 6061-T6 Aluminum Alloy Tubing		Repair Kit
Inserts:	5/8" O.D. 6061-T6 Aluminum Alloy Tubing		Travel-style Backpack
Stern Deck Bar:	7/8" O.D. 6061-T6 Aluminum Alloy Tubing		Assembly Video and Written Instructions
Rivets and Spacers:	Aluminum and Nylon		Flip-Up Surf Rudder
Screws and Bolts:	Stainless Steel		Bow-Line
Protective Coating:	Clear Anodized		Shockcord Cross-deck Tie-downs
Deck:	Polytech		Perimeter Deck Line
Hull:	Duratek		

# K1 Frame: 6061-T6 Anodized Seamless Drawn Round Tubing

Crossribs and Keel Plates handcrafted from High Density Polyethylene

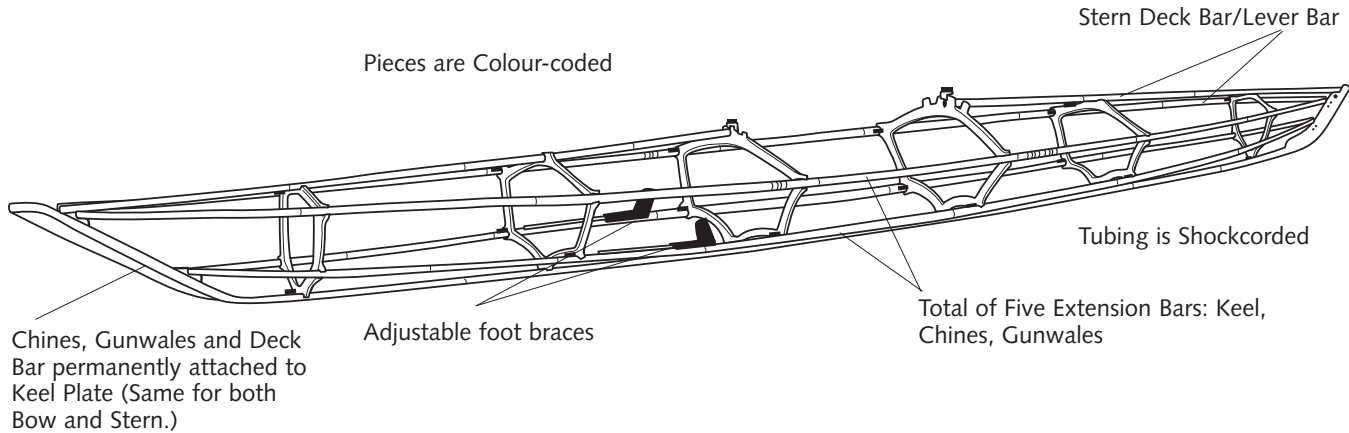

# Care and Maintenance

## The Frame.

The tubular frame is very strong and corrosion resistant. We recommend that the frame be disassembled after extensive use (2 – 3 months). The inside and outside of the tubes should be washed with fresh water. Try to keep the inserts and extension bars free of sand and grit.

Included in your repair kit is a small dropper tube of Bo-Shield T-9. This product is made by Boeing and is an excellent lubricant and protectant for aluminum.

Aerosol containers of Bo-Shield can be found at marine hardware stores. We also have available 4 oz bottles of Bo-Shield. However, please note, that the lid closure is not suitable for shipping after the bottle has been opened. This container would be good for your “at home” clean-up. We also have available Super Lube. This is a teflon lubricant in gel form. This product is also available from bike shops.

Apply the Bo-Shield lubricant to frame tube inserts, spring buttons and sliding pieces prior to assembly. If you should leave your boat assembled for a maximum of two months, this will assist in preventing tubes seizing.

Other maintenance “musts”:

- every two months completely disassemble the kayak.
- wash the frame completely with fresh water.
- reapply lubricant and/or wipe down tubes with Bo-Shield T-9.
- after paddling, sponge out the inside of the kayak. Do not allow water to pool along keel bar.

## The Skin

The Polytech deck and Duratek hull are urethane. Seams are permanently sealed.

A patch kit is provided for deck, hull or sponson punctures. One urethane glue will work for repairs to all of these fabrics.

## Tie-Downs

Webbing straps across the stern will secure a spare paddle. Shockcord in front of the cockpit is handy for holding a chart. Loops which secure the perimeter line can be used for lashing additional gear to the deck.

## Sponsons

Due to the tight fit of the skin, the sponsons are under considerable pressure and some seepage of air may occur. It is advisable to periodically reinflate the sponsons. After paddling on hot days, release air from sponsons.

### To Repair/Replace Sponson

The sponsons can be completely removed from the sleeve sewn to the inside of the skin. Turn the skin inside out. The sponson chamber is open at bow and stern ends. Tie a long string through the hole in the tab at each end of sponson. Pull sponson through the center opening of the chamber (where sponson hose is attached). To reinstall, pull the cord attached to the new sponson back through the chamber. Ensure sponson is not twisted in the chamber. Urethane glue and patches are included in the repair kit. Duct tape works well on the sponsons.

## Lifting the Kayak

The webbing handles at the bow and stern can be used to lift or carry. **Never lift or carry a fully loaded kayak.**

## Storage

Once clean and dry, the kayak can be stored assembled or disassembled in a shaded, dry place. When storing the kayak disassembled, take extension bars apart.

# K1 Expedition Assembly Instructions

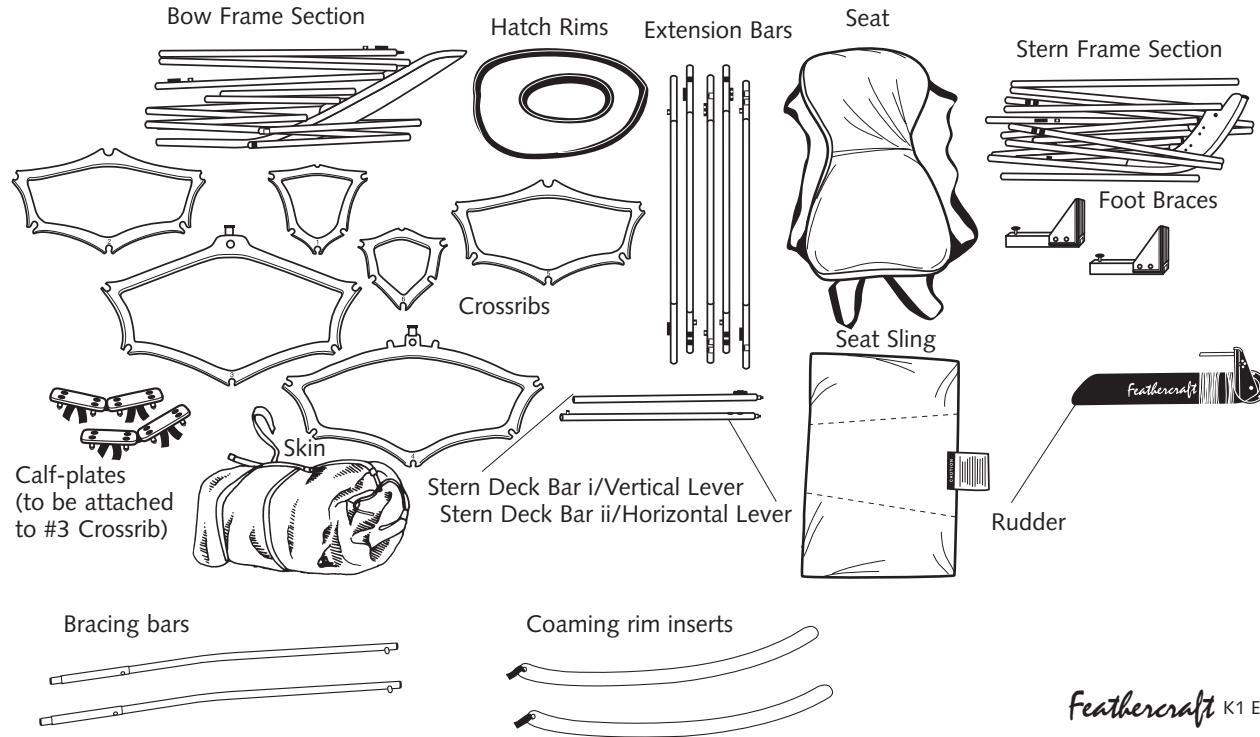



Bow Frame Section

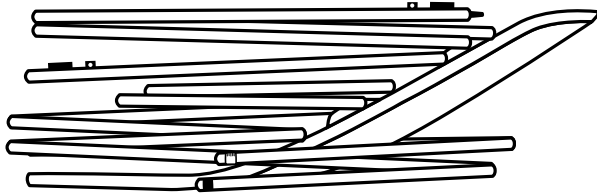

Stern Frame Section

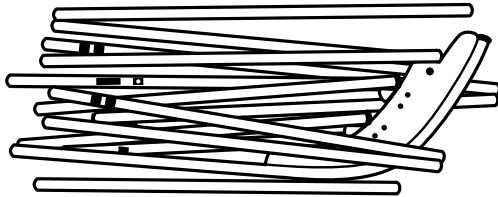

- 1 SET OUT FRAME PARTS AS ILLUSTRATED ON THE PREVIOUS PAGE.
- Bow frame tube sections are permanently attached to the bow keel plate, and the tube sections are shock-corded together. The bow keel plate is pointy.
  - The bow section has a single band of colored tape, and foot-track is attached to the chine tubes.
  - Stern frame tube sections are permanently attached to the stern keel plate, and the tube sections are shock-corded together. Stern frame sections have two bands of tape.
  - There are five extension bars, and six high density polyethylene crossribs. Each one is numbered.

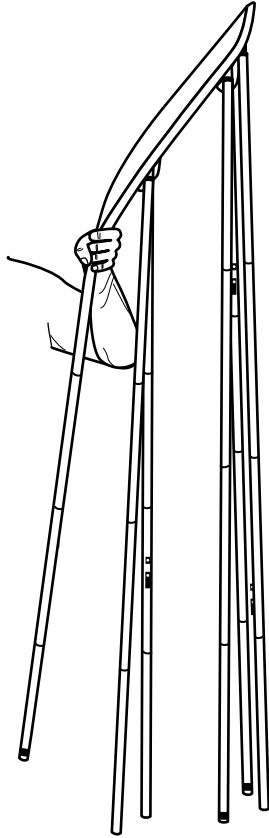

2 FOLD OUT BOW FRAME SECTION.

- “Shake out” bow section.
- Note foot-track on chine tubes.
- Shock-corded tubes sections join together.

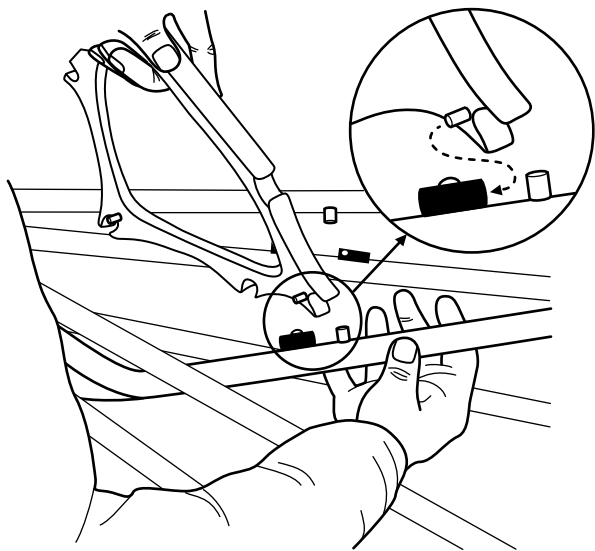

**3 ATTACH #1 CROSSRIB TO BOW SECTION.**

- Pin on bottom of #1 crossrib is inserted into hole in plastic block on keel tube.
- Chine tubes snap into place in crossrib.
- Gunwale tubes are secured with twister block.

**4 ATTACH #2 CROSSRIB TO BOW SECTION.**

- a) Insert pin on bottom of crossrib in plastic block as you did in Step 3.
- b) Attach chine and gunwale tubes to crossrib with twisters.

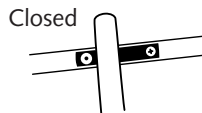
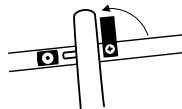
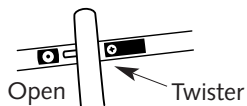

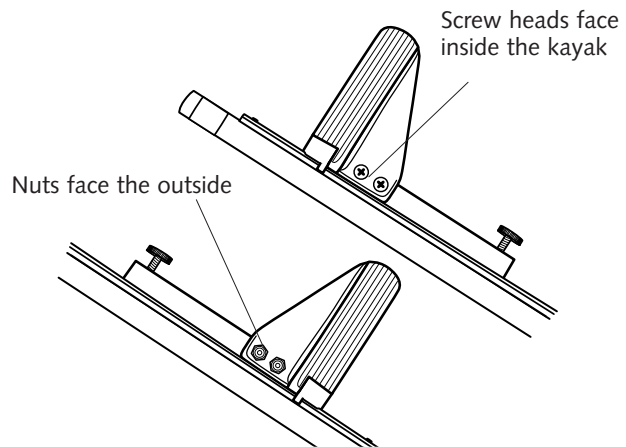

5 SLIDE ON FOOT BRACES.

- Note the orientation of the nut and screw heads on the side of the foot braces.

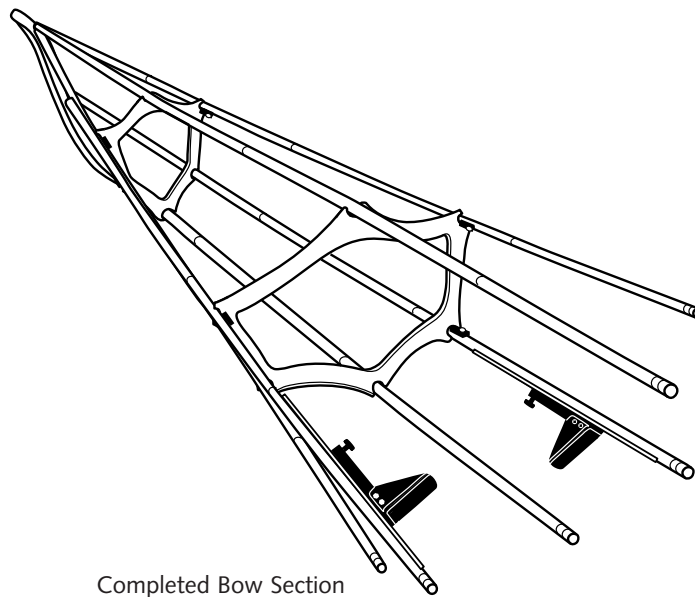

- 6 FOLD OUT STERN FRAME SECTION.
  - “Shake out” stern frame section as you did with the bow section in Step 2.
  
- 7 ATTACH #6 CROSSRIB TO STERN SECTION
  - Follow the same procedure as you did in Step 3.
  
- 8 ATTACH #5 CROSSRIB TO STERN SECTION
  - Follow the same procedue as you did in Step 4.

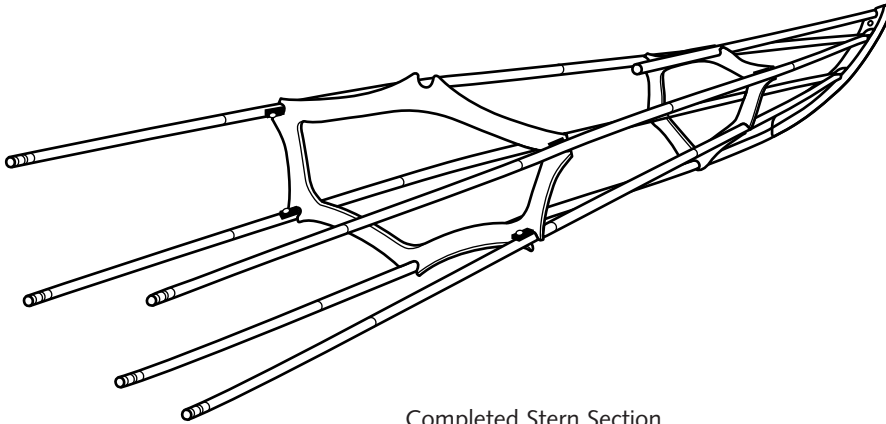

Completed Stern Section

9 UNFOLD THE SKIN.

Note: The rudder bracket is permanently attached to the stern end of the kayak skin.

(The bow end has the Feathercraft logo.)

There are three Velcro-tab closures on the inside of the hull:

- one can be reached through the bow hatch;
- one through the stern hatch;
- and one located in the cockpit opening.

Have all of the Velcro-tabs OPEN.

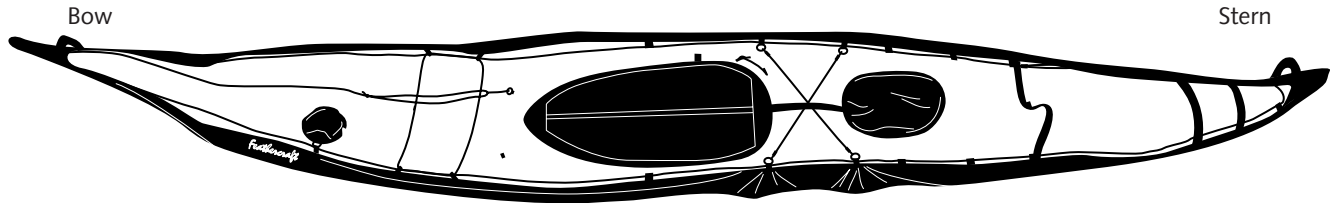

**10 INSERT BOW FRAME SECTION INTO SKIN.**

- Insert bow frame section through the cockpit opening, using a slide/lift motion. Reach through the bow access hatch, centering the frame, using the Velcro tabs as guides. Snug the bow frame section to the very tip of the skin. Align and centre the frame. Secure Velcro closure around the keel bar.

**11 INSERT STERN FRAME SECTION INTO SKIN.**

- Insert stern frame section through the cockpit opening, as you did with the bow section in step 11. Align and centre the frame. Secure Velcro closure around the keel bar.

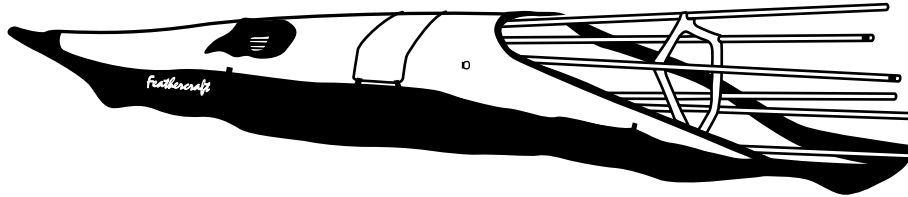

Note: During additional assembly steps, keep re-checking that the frame has remained centered in the skin.

## 12 INSERT KEEL EXTENSION BAR.

- Slide the stern end of the extension bar on to the stern keel bar (the end with two stripes of black tape). Slide the bar apart, and attach the other end to the bow keel bar.

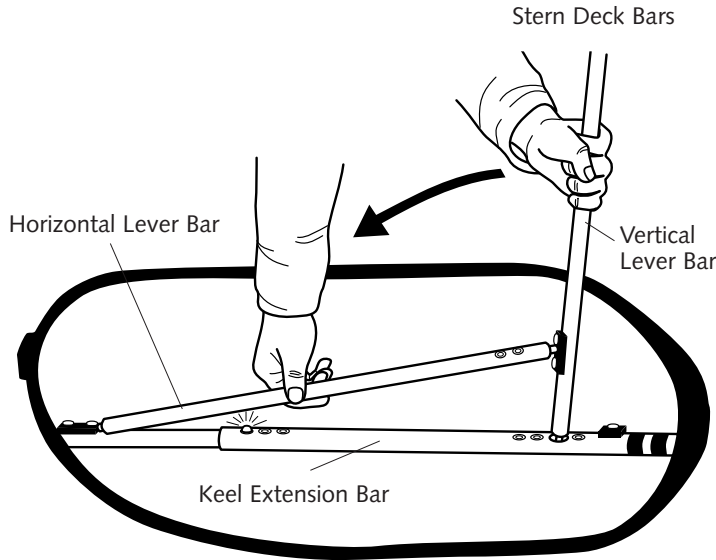

- An additional “pusher” block has been installed on the bow keel bar. If the bow and stern sections need to be separated further to insert the keel bar, push against this block using the lever bars.
- Expand the extension bar using the two stern deck bars—vertical and horizontal lever bars.
- Push on stern deck bar ii (in direction indicated). This forces the keel extension bar to expand. Open till the spring button pops up in the first hole.

## 13 INSTALL CHINE EXTENSION BARS.

- Note: When installing frame parts in the kayak it is easier to be situated on the opposite side from the part you are installing.
- Install chine extension bars (yellow and blue) as you did the keel extension bar. Extend till the spring button pops up in the first hole.
- As the frame parts are beginning to take the curve of the skin, it may be necessary to pull tubes into alignment so they can slide easily. Pull extension and stern frame tube towards the center of the kayak, lining them up.



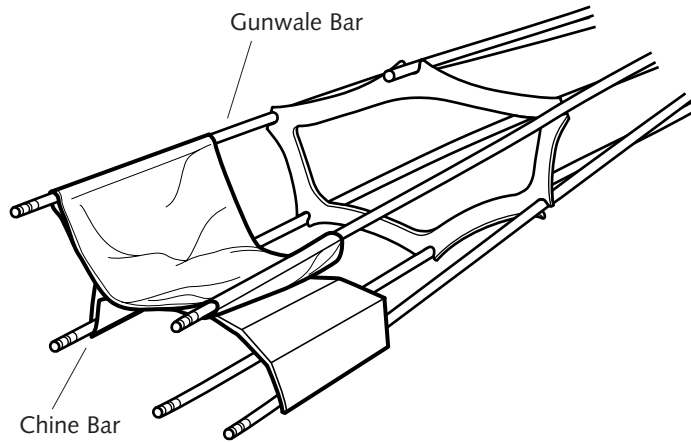

(Seat sling installation shown without skin for illustration purposes.)

#### 14 ATTACH SEAT SLING.

- The seat sling is made of black packcloth. The upper part has two looped sides. The stitching at the front of the seat sling is wider than at the back.
- Slide the Gunwale extension bars (red and green) through the looped sides, ensuring the two stripes of tape are at the stern.
- Attach the Gunwale bars as you attached and installed the keel and chine bars. Use the lever bars again to extend the gunwale extension bars. Extend till the spring button pops up in the first hole.
- Extend Keel and Chine bars to second hole. Depress spring button, lever tubes until spring button appears in second hole. Extend gunwales to second hole.
- The bottom side sections of the seat sling are a Velcro-Sandwich. Slide and secure bottom section around chine bars.

15 INSTALL RIM INSERTS

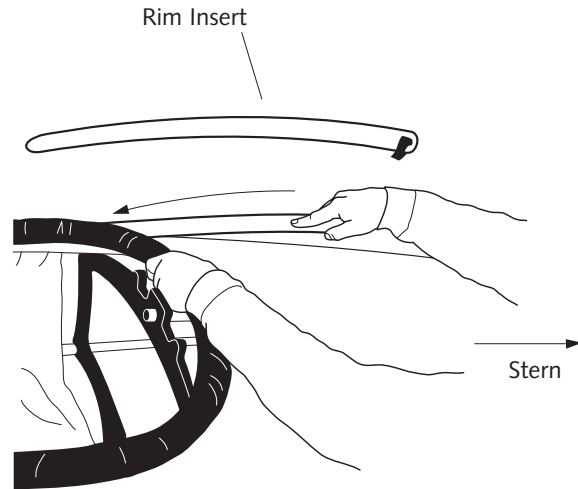

Slide into pocket on underside  
of coaming rim.

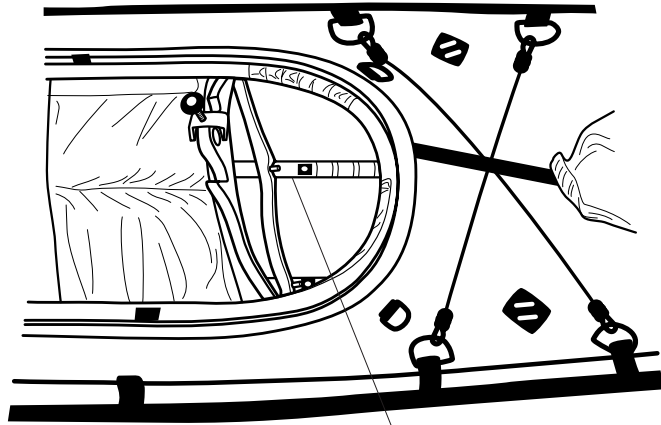

Pins insert into delrin blocks

**Note:**

(Lever bar can be used to assist in turning tubes into alignment by inserting pin into extension hole and rotating tube slightly.)

**16 INSERTING #3 AND #4 CROSSRIBS.**

- The pins on the crossrib will be inserted to delrin blocks mounted on frame tubes. Insert crossrib through cockpit opening at an angle then rotate. Orient the pins towards the delrin blocks.
- Set crossrib into place. Depress spring button with one hand; use thumb to push rib forward. Turn bar to line up delrin block with hole to insert pin on crossrib. Start on one side and work your way around the rib, installing each pin in turn.

This system is the same for both the #3 and #4 crossribs.

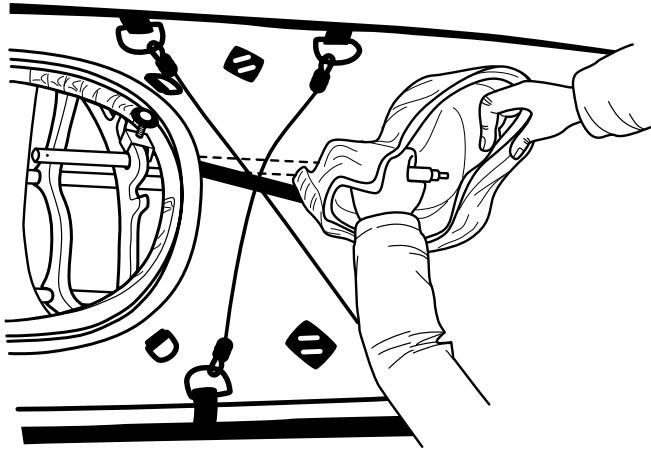

17 **INSTALL STERN DECK BARS.**

- Connect Stern Deck Bar i/Vertical Lever to single tube deck bar attached to stern frame section.
- Slide Deck Bar ii/Horizontal Lever through hole in top of #4 crossrib.
- Join to deck bar that is attached to stern section.
- Install coaming knob so that screw inserts into deck bar.

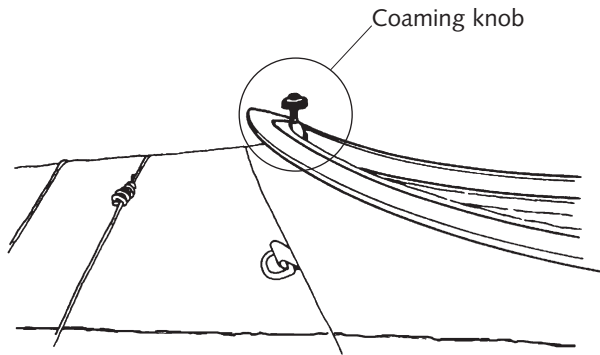

**18 INSERT BOW DECK BAR.**

- Fit the bow deck bar section through the hole in the top of the crossrib.
- Replace coaming knob.

**19 INSTALL THIGH BRACES**

Slide oversleeve on thigh brace towards bow. Insert stern end of tube (a) through hole in large stern crossrib. Insert bow end (b) through hole in large bow crossrib. Slide oversleeve towards stern till spring button appears in 2nd hole.

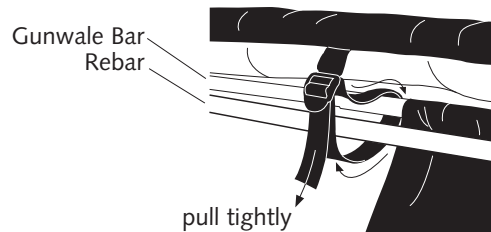
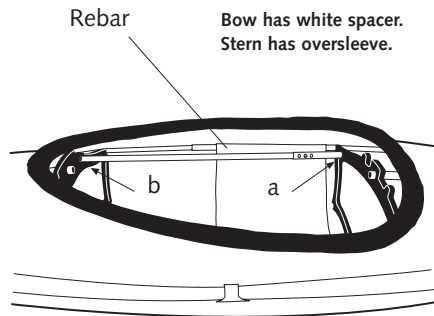

Rebar is secured with web strap.

## 20 CONNECTING RUDDER CONTROL TO FOOT BRACE.

- Red webbing adjusters are connected to the foot brace. Unscrew thumb-knob on footbrace; stem of knob goes through grommet. To make the adjuster shorter, fold webbing over to second grommet. Re-attach knob to foot brace. Slide brace on to track. Ensure brace can slide easily on track. (If not, check knob that you re-attached.) If additional leg extension is required, the foot plate on the brace can be reversed.

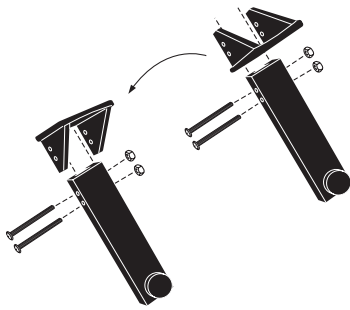

### CABLE LENGTH ADJUSTMENT

- To shorten cable length, pull on tab of webbing with loop. To lengthen, lift tab of ladder-lock buckle.

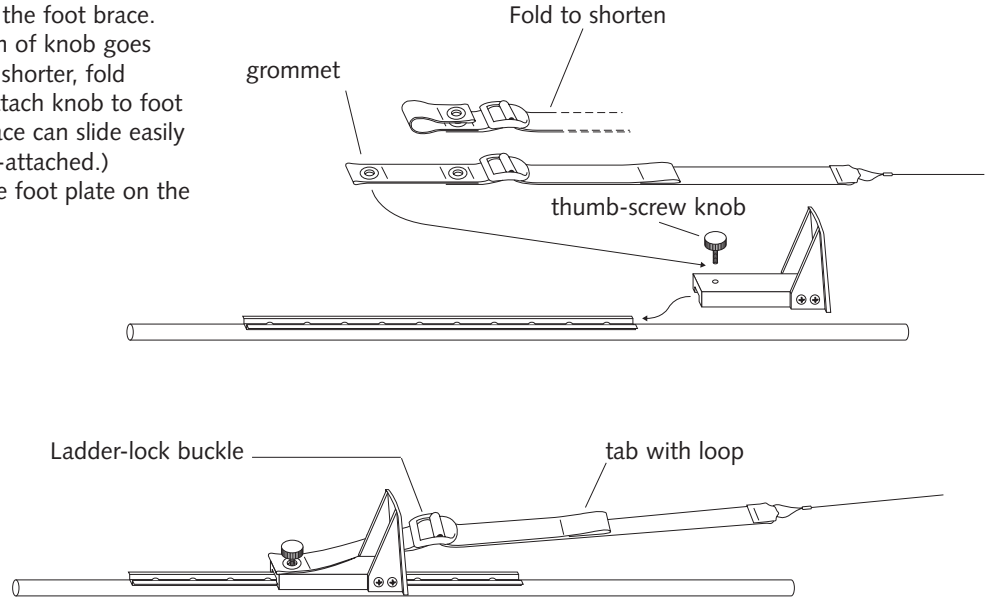

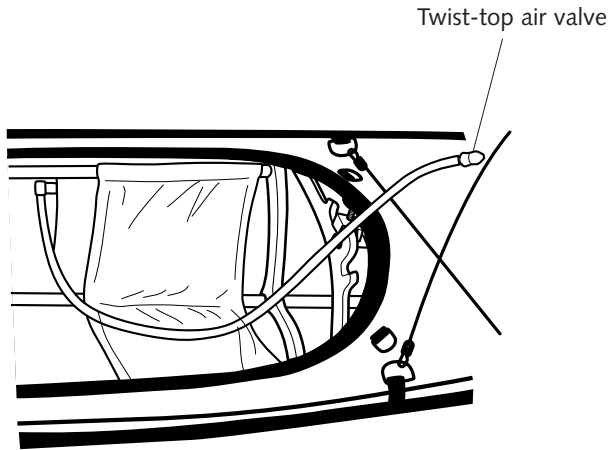

#### 21 INFLATE SPONSONS.

- Turn the top of the valve to open. When inflating sponsons, alternate sides to ensure the frame and skin remain centered. The air pressure from the sponsons can shift the frame within the skin. Keep blowing until the skin is nice and tight. Twist top cap to close. Tuck sponson tubes and valves out of the cockpit area. Avoid stepping on the hose and valve, and try to keep the valve free of sand.

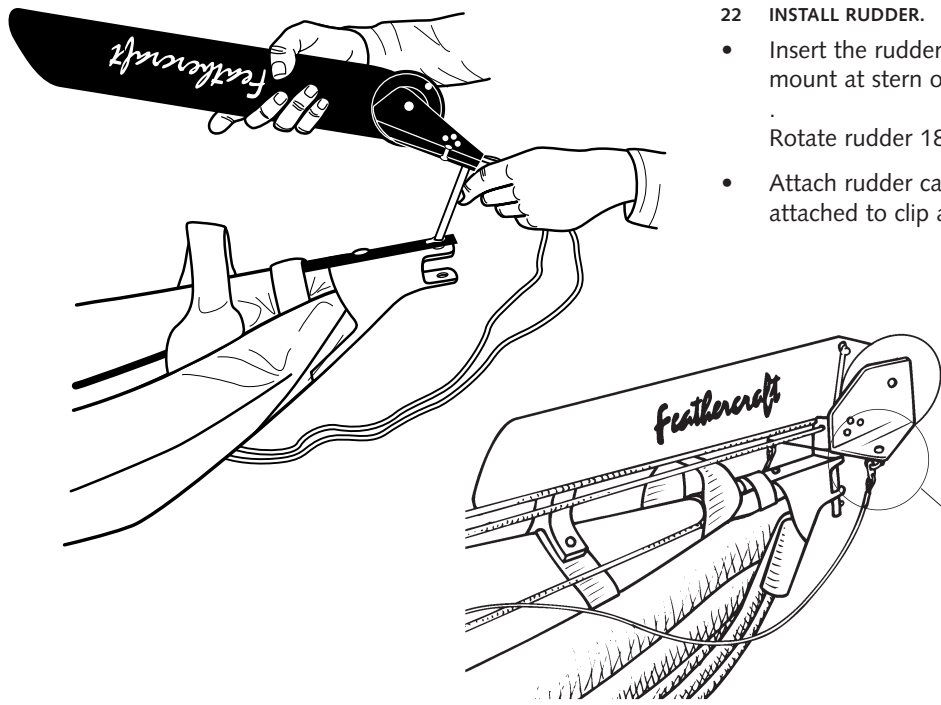

22 INSTALL RUDDER.

- Insert the rudder pin through the “key hole” on rudder mount at stern of kayak

Rotate rudder 180°.

- Attach rudder cables with sister clips. White haulcord is attached to clip at the side of the cockpit.

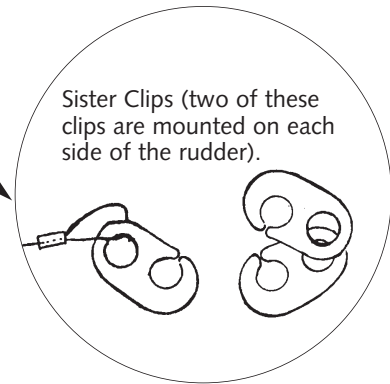



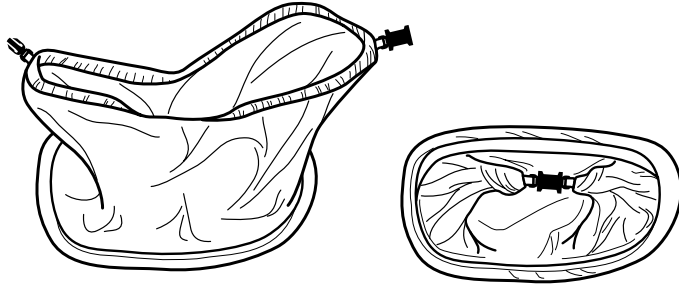

**23 ATTACH HATCH RIMS.**

- Attach hatch rims by folding the fabric sleeves sewn to the deck over the rim. Roll down inner closure and close with buckels. Place hatch cover over rim and secure with B-locks.
- During disassembly, don't forget to take the plastic rims off. Don't roll the skin up with the rims still in place.

**24 ATTACH CALF-PLATES TO #3 CROSSRIB WITH VELCRO**

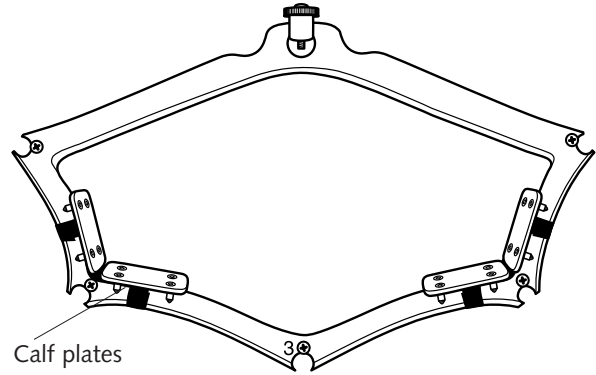
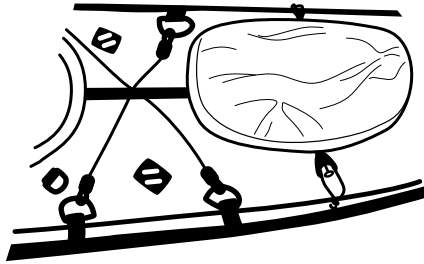

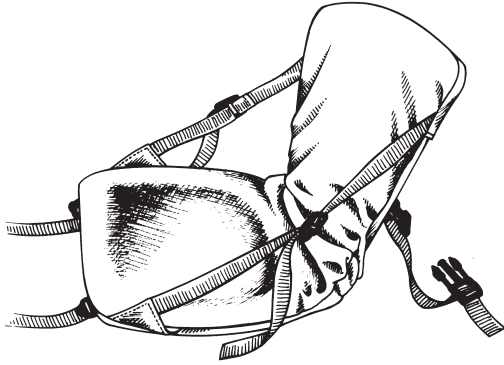

**25 INSTALL SEAT.**

- Loop the webbing attached to the seat back around the top of #4 crossrib. Attach buckle and make any adjustments. Slider buckles attached to webbing at the side of the seat gives the paddler additional fitting adjustments.
- The long pieces of webbing attached to the front of the seat bottom are looped around the base of the #3 crossrib and secured with buckle. Do not cinch these too tight; allow some slack for shifting the seat.

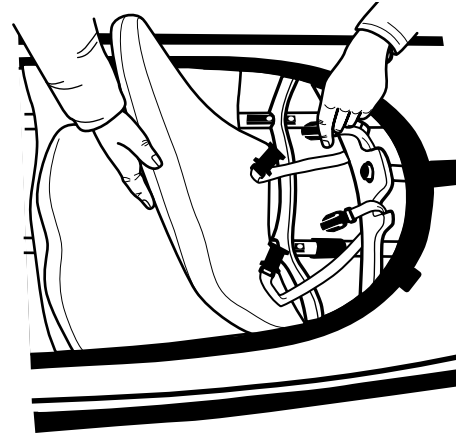

## 26 DISASSEMBLY AND REPACKING THE BACKPACK.

Let the air out of the sponsons. Remove Cockpit Rim inserts and Hatch Rims. Remove bracing bars. Remove deck bar/lever bars. Remove large bow and stern crossribs. Using the lever bars, release the tension on the Chine and Gunwale Extension bars. Release the Keel Extension last. Follow the rest of the assembly steps in reverse order.

To fold the skin up to the most compact roll:

- a) have the sponson valves open, and pull the sponson hoses out to the side of the skin
- b) fold the ends into the cockpit; twist them so they lay flat
- c) fold in half
- d) begin rolling the skin at the open-fold-edge; roll it up like you would a thermarest, kneeling on the roll as you go
  - close sponson valves; tuck these into the folded skin
  - cinch the roll with the webbing ties

Packing the the Kayak in the bag:

Put the seat cushion in the bag first, with the cushion facing down, to give padding for your back. Next arrange the white plastic crossribs and hatch rims over the seat. Roll the kayak skin up tightly; secure with webbing straps. Place skin in center of bag. Bow and stern frame “bundles” are placed on either side of skin. All additional pieces are placed as room permits.

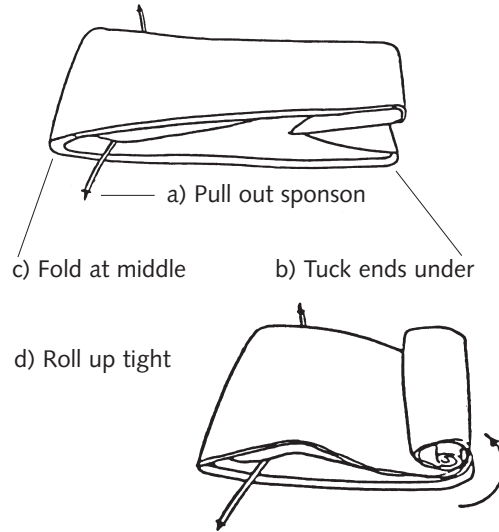

## The Feathercraft Sea Sock

Made from high-quality coated nylon, the sea sock is a great safety item. The top of the sock fits tightly around the cockpit coaming rim. Contoured to fit along the seatback and bottom, the “foot” is loose through the cockpit, creating a “pod”. The paddler then sits in the sock. Legs and feet are not constricted. The spray skirt fits as usual. In the event of a capsize, water will only enter the sock, and not the whole boat. It's also great for keeping the inside of your kayak clean.

## Tips on Usage and Installation

- The shiny side of the fabric faces in towards the kayak frame.
- When facing the bow of the kayak, the Feathercraft label should be on the right side.
- The center seam on the up-side of the Sea Sock should be centered on the bow point of the coaming.
- Once the Sea Sock is in place, sit in the sock, and “burp” it by lifting the edges, releasing trapped air that causes the sock to billow up.

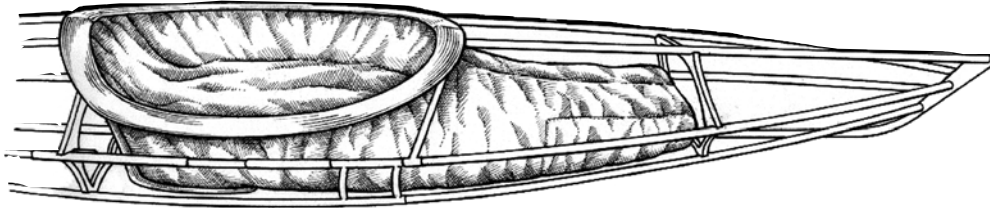

© Feathercraft Products Limited 1998  
Printed in Canada 12.2005  
Recycled paper

