

YOUR ADVENTURE UNFOLDS

K-Light Classic

2008

Feathercraft
FOLDING KAYAKS™

Feathercraft Products Ltd. 4-1244 Cartwright Street on Granville Island, Vancouver, British Columbia, Canada V6H 3R8
Telephone: (604) 681-8437 Fax: (604) 681-7282 www.Feathercraft.com info@feathercraft.com

Contents

K-Light Single Folding Kayak	Page 2
Specifications	Page 3
K-Light Frame.....	Page 4
Care and Maintenance	Page 5
Disassembly	Page 6
K-Light Assembly Instructions.....	Page 8
The Feathercraft Sea Sock.....	Page 21
Optional Rudder Installation	Page 22
Optional Hatch Installation	Page 26

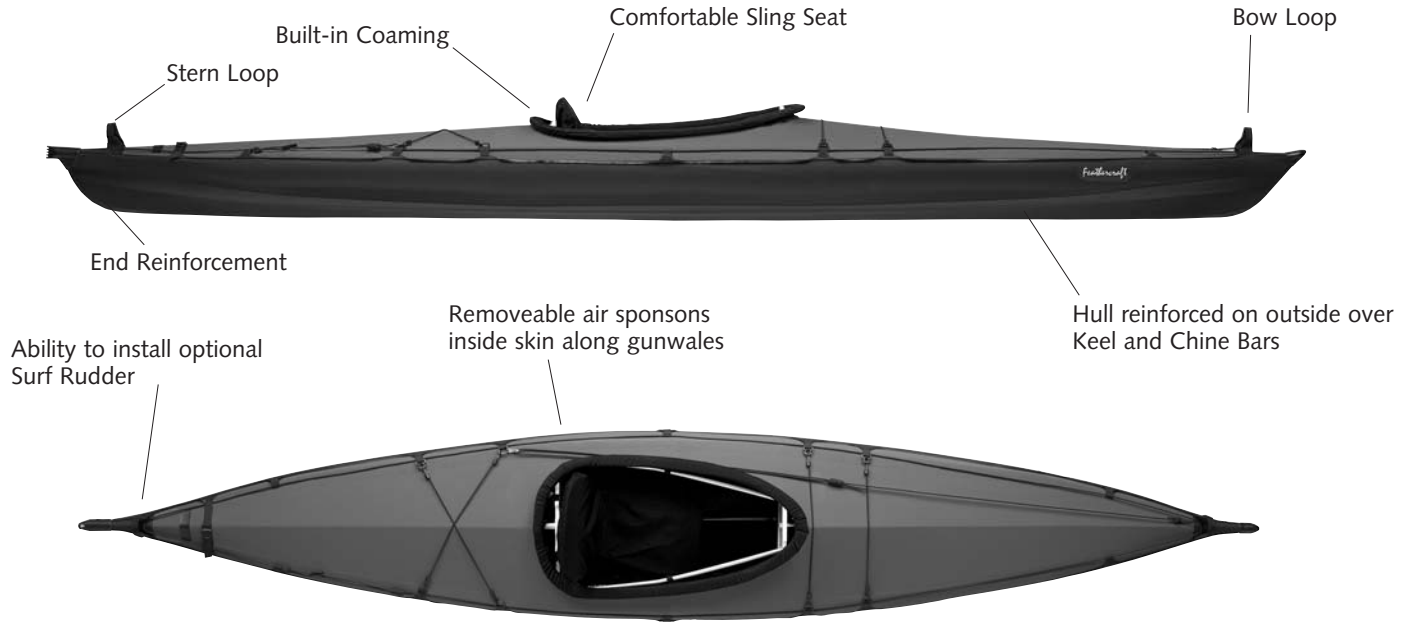

The K-Light Classic Single Folding Kayak

Specifications

Length:	3.9 m (12'10")
Beam at Cockpit:	64 cm (25")
Weight:	15.5 kg (34 lbs)
Pack size:	89 x 50 x 25 cm (35 x 20 x 10")
Storage Volume:	Medium
Frame:	5/8" Round 6063 - T832 Extruded Aluminum Magnesium Tubing with clear Anodized Coating
Crossribs:	Injected Molded Polycarbonate
Deck Material:	Polytech
Hull Material:	Duratek
Seat:	1/2" closed cell foam back & bottom, contoured plastic seat bottom, 3/16" plastic seat back with inflatable lumbar support, inside a 420 denier nylon seat cover

Accessories:	Included in every kayak: Nylon Spray Skirt Sea Sock Deck Lines and Rigging Adjustable Foot Braces/Rudder Controls Repair Kit Pack Bag Assembly DVD Illustrated Instructions
--------------	---

Options:	Access hatches Surf rudder Neo-nylon spray skirt Calf plates
----------	---

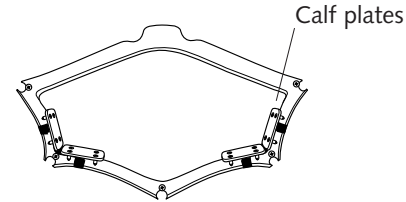

K-Light Frame

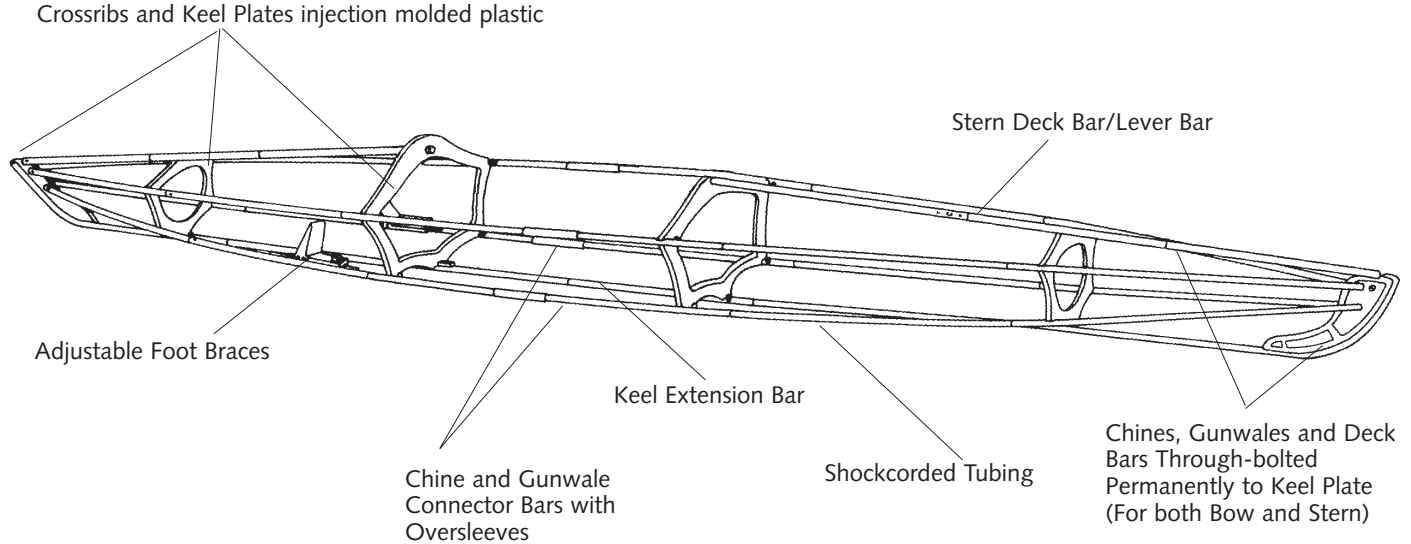

Care and Maintenance

The Frame.

The tubular frame is very strong and corrosion resistant. We recommend that the frame be disassembled after extensive use (2 – 3 months). The inside and outside of the tubes should be washed with fresh water. Try to keep the inserts and extension bars free of sand and grit.

Included in your repair kit is a small dropper tube of Bo-Shield T-9. This product is made by Boeing and is an excellent lubricant and protectant for aluminum.

Aerosol containers of Bo-Shield can be found at marine hardware stores. We also have available 4 oz bottles of Bo-Shield. However, please note, that the lid closure is not suitable for shipping after the bottle has been opened. This container would be good for your “at home” clean-up.

Apply the Bo-Shield lubricant to frame tube inserts, spring buttons and sliding pieces prior to assembly. If you should leave your boat assembled for a maximum of two months, this will assist in preventing tubes seizing.

Other maintenance “musts”:

- every two months completely disassemble the kayak.
- wash the frame completely with fresh water.
- reapply lubricant and/or wipe down tubes with Bo-Shield T-9.
- after paddling, sponge out the inside of the kayak. Do not allow water to pool along keel bar.

The Skin

The surfaces of the skin will not rot. They are stable in sunlight and are very tear-resistant. On the hull, areas likely to be exposed to abrasion have been reinforced. However, we recommend care when approaching shore. Sharp rocks, and barnacles can penetrate the skin. Never haul the boat over rocks.

For patching and repairs, a patch kit is included. For quick field repair, duct tape works very well, and is a good addition to your repair kit.

Welded Sealskin.

The Polytech deck and Duratek hull are urethane. Seams are permanently sealed.

A patch kit is provided for deck, hull or sponson punctures. One urethane glue will work for repairs to all of these fabrics. Glue does have a shelf life and it should be fluid and not thick and gummy. We have replacement cans available.

Sponsons

Due to the tight fit of the skin, the sponsons are under considerable pressure and some seepage of air may occur. It is advisable to periodically reinflate the sponsons. After paddling on hot days, release air from sponsons.

To Repair/Replace Sponson

The sponsons can be completely removed from the sleeve sewn to the inside of the skin. Turn the skin inside out. The sponson chamber is open at bow and stern ends. Tie a long string through the hole in the tab at the end of sponson. Pull sponson through the center opening of the chamber (where sponson hose is attached). To reinstall, pull the cord attached to the new sponson back through the chamber. Ensure sponson is not twisted in the chamber. Repeat with the opposite side. Urethane glue and patches are included in the repair kit. Duct tape works well on the sponsons.

Disassembly

Let the air out of the sponsons. Remove Cockpit Coaming. Remove Gunwale and Chine Connector bars. Install Stern Deck Bar into Keel Extension Bar. Take up tension with the Lever in order to remove the Keel Extension Bar. Follow the rest of the assembly steps in reverse order.

Packing the kayak in the bag

Put the seat cushion in the bag first, with the cushion facing down, to give padding for your back. Next arrange the white plastic crossribs over the seat. Stretch the sprayskirt over the fibreglass coaming. Place this in the bag, over the crossribs. Roll the kayak skin up tightly—fold the ends to the center of the kayak; fold in half; roll tightly; secure with webbing ties. Place this bundle in one side of the bag. Put aluminum frame parts along side of the rolled up skin. Tuck all additional pieces (ie: sea sock, repair kit) into any available space.

Lifting the Kayak

The webbing handles at the bow and stern ends can be used to lift or carry. **Never lift or carry a fully loaded kayak.**

Storage

Once clean and dry, the kayak can be stored assembled or disassembled in a shaded, dry place. When storing the kayak disassembled, take extension bar apart.

K-Light Classic Assembly Instructions

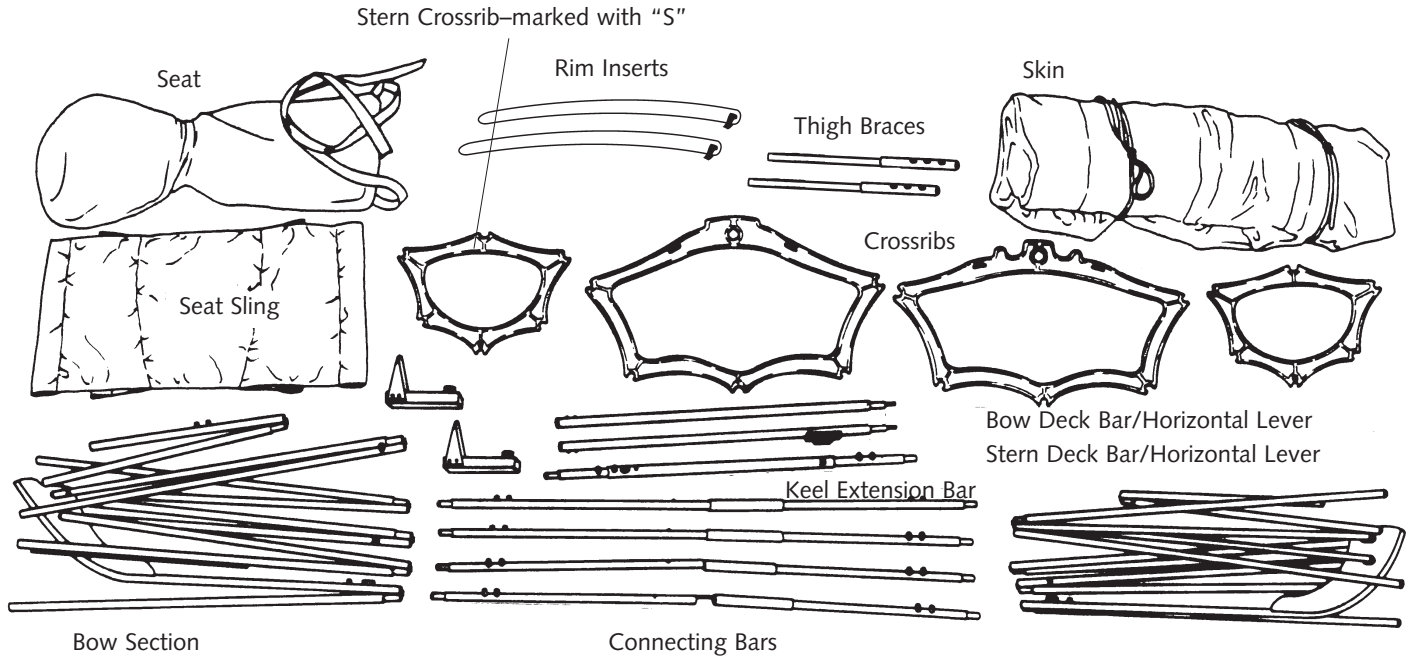

- 1 SET OUT FRAME PARTS AS ILLUSTRATED ON THE PREVIOUS PAGE
- 2 BOW SECTION
(has foot track installed on chine bars).
 - “Shake out” bow section. Shock corded tubes take shape.

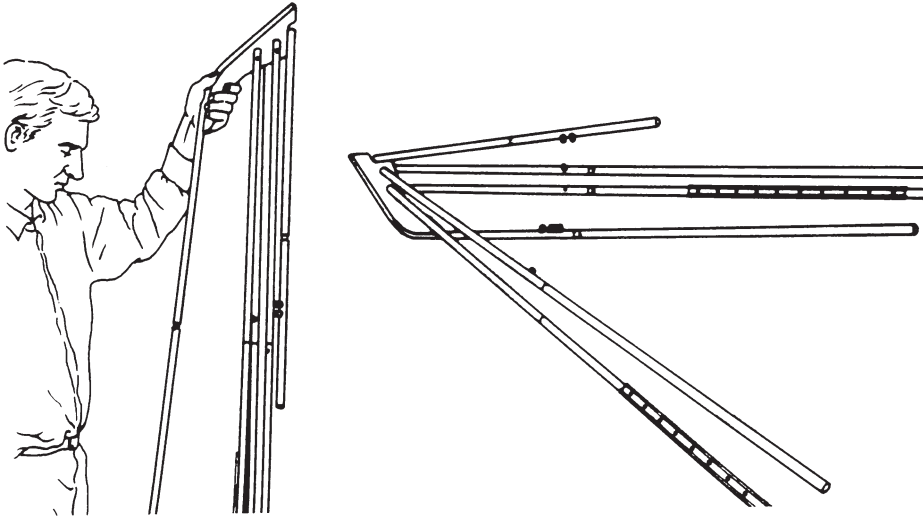

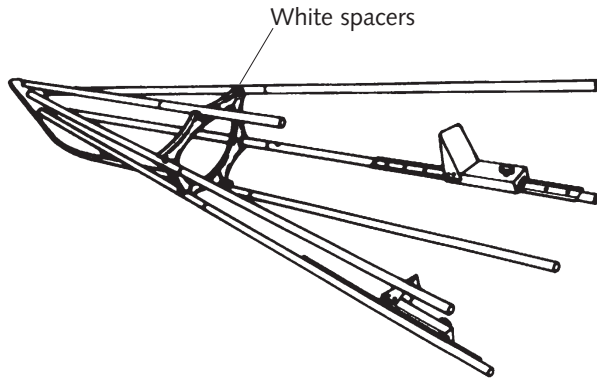
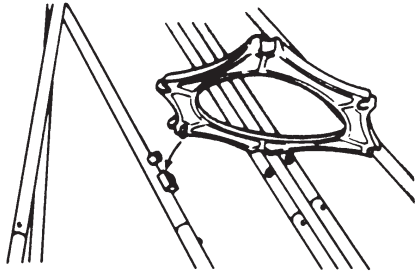

3 ATTACH SMALL CROSSRIB TO BOW SECTION.

- Pin on small crossrib is inserted into hole in plastic block on keel tube; fit into place.
- Snap chine and gunwale tubes on to crossrib. When the crossrib is in position, the white spacers are on the "cockpit" side of the crossrib.

4 COMPLETE BOW SECTION.

- Slide foot braces on to track.

5 STERN SECTION.

- Repeat Step #2 and #3.

6 UNFOLD SKIN.

- There are two Velcro-tab closures on the inside of the hull. These are located through the main cockpit opening, bow and stern.

7 INSERTING FRAME SECTIONS TO SKIN.

- Before inserting the frame into the skin, ensure the velcro tabs are open. Slide the bow and stern frame sections into the skin. (Feathercraft label is on the bow end.)
- When inserting the frame sections, align and centre the frame using the tabs as guides. Snug the frame sections to the very tip of the skin. Secure Velcro closure around the keel bar.

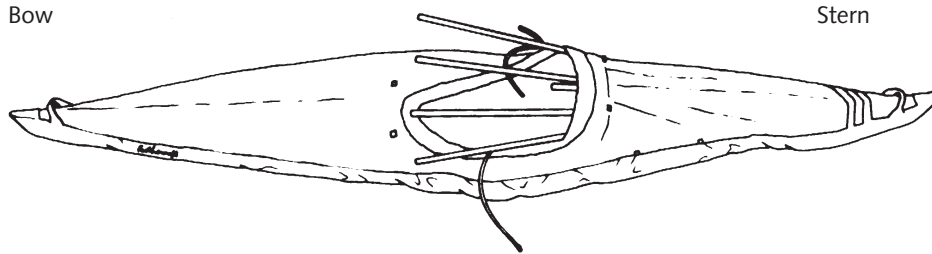

8 INSTALL KEEL EXTENSION BAR.

- Slide the stern end of the extension bar on to the stern keel bar. Slide the bar apart, attaching the other end to the bow keel bar.

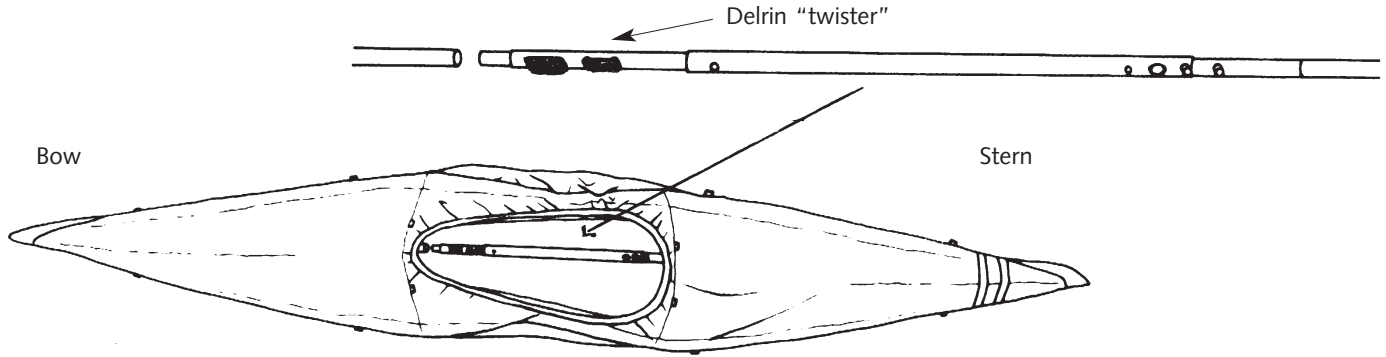

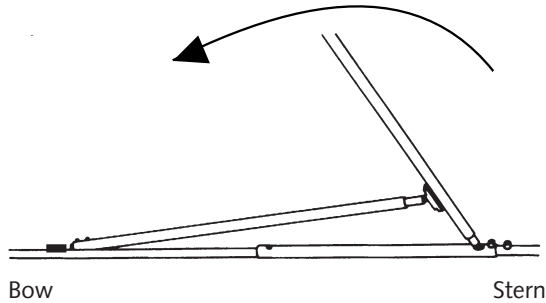

9 EXPAND EXTENSION BAR.

- Lever keel extension using Stern Deck Bar/Vertical Lever and Bow Deck Bar/Horizontal Lever. Expand until spring button pops up.
- Expand keel to second or third hole. You should feel resistance, but not be using extreme force.

10 INSTALLING RIM INSERTS.

- Slide into pocket on underside of coaming rim.

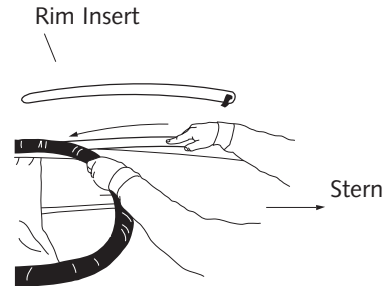

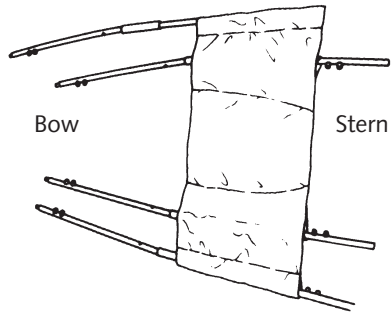

11 INSTALL SEAT SLING.

- Stern end of seat sling has narrower stitching. Slide Connecting Bars through loops in sling with oversleeve tubes oriented towards the bow.

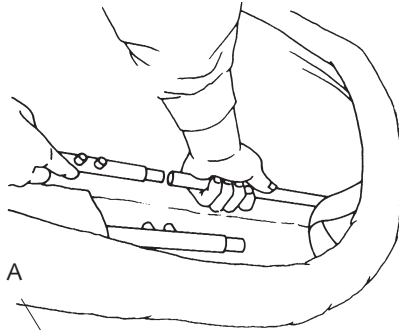

A

Pull tubes "in-line" to each other to slide easier.

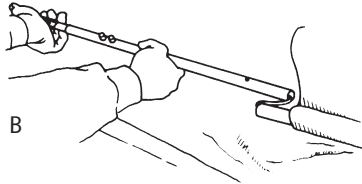

B

Shockcord is extended. Tubes are "overlapped".

Bring mid-connector tubes "together".

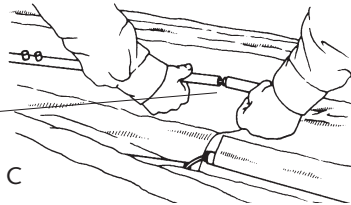

C

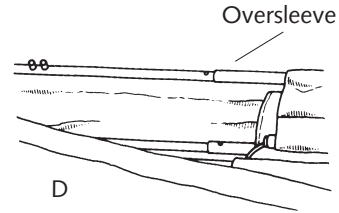

D

Note: When installing frame parts in the kayak, it is easier to be situated on the opposite side from the part you are installing.

12 INSTALL MID-CONNECTORS.

- Once the bow and stern frame sections have been inserted to the skin, they begin to take the curved shape of the kayak. It will be easier to slide tubes together when the tubes are in a straight line to each other.
- When beginning to install the mid-connectors, pull the stern chine bar towards the center of the kayak. Slide on stern end of mid-connector. Pull bow section of mid-connector forward, extending shockcord. Mid-connector tubes will be "overlapped". Pull bow chine tube to center of skin to bring in line to mid-connector. Slide bow end of mid-connector on to chine bar.
- With both ends of the mid-connector now attached to the chine tubes, push the mid-connector "out" towards the outside of the skin. When the mid-connector tubes are in line, pull back towards the center of the skin, and slide sleeve over join.

Note: This step is done when frame is in the skin.
For illustration purposes, we have shown it without the skin.

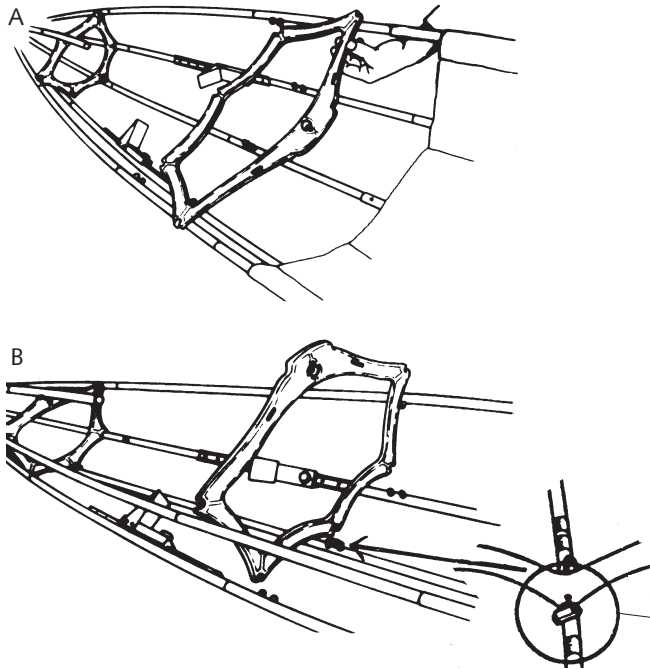

13 INSTALLING LARGE CROSSRIBS.

- Position large crossrib to lay on top of gunwale tubes. Slide forward towards pins on gunwale tubes. Rotate crossrib into position.
- Place crossrib between gunwale pins nearest you by pushing gunwale bar up over end of crosspiece and snapping into position.

FOR BOW CROSSRIB:

- There are two black plastic blocks mounted on the keel bar. One is mounted with a screw and can be rotated. When rotated away from the other block, it is in the "open" position. Have the block set in the "open" position.
- Insert pin located on bottom of crossrib into stationary black block on keel bar. Twist the second block into the "closed" position. Snap crosspiece into position on gunwales, then chines.

14 REPEAT STEP 13 FOR INSTALLATION OF STERN CROSSRIB.

- Procedure is the same, except for twister.

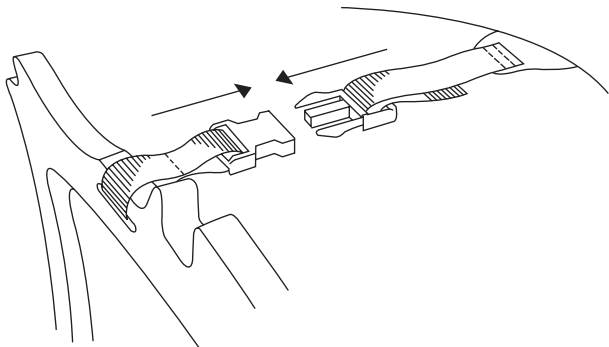

15. SECURE DECK WEBBING TO CROSSRIBS.

- Attached to the underside of the deck, behind the large stern crossrib, are pieces of webbing with buckles.
- Clip to the corresponding buckle attached to the crossribs.

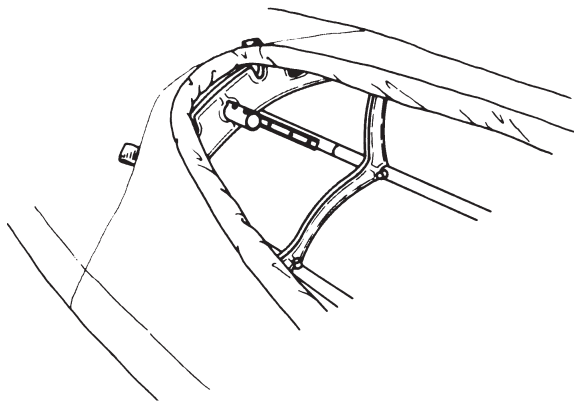

16. INSTALL BOW DECK BAR.

- Insert through small hole in top of large crossrib.
- Join to shockcording deck bar.
- Hold through deck.
- Turn to lock into place.

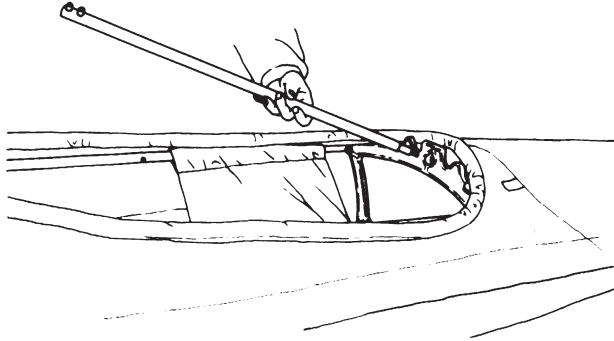

17 INSTALL STERN DECK BAR.

- Put the stern deck bar through the center of the large crossrib: end with black block pointing towards the stern.
- Bring deck bar end closest to you, back through small hole in top of crossrib.
- Line up bar, and insert to shockcorded deck bar. Hold the shockcorded deck bar through the deck while turning the deck bar to lock into place (as you did in Step #15).
- Ensure spacers on the deck bar do not face upward, pushing against inside of the deck.



18 INSTALL THIGH BRACES.

- Slide oversleeve on thigh brace towards bow. Insert stern end of tube (a) through hole in large stern crossrib. Insert bow end (b) through hole in largebow crossrib. Slide oversleeve towards stern till spring button appears in 2nd hole.

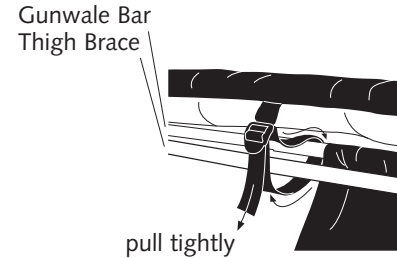
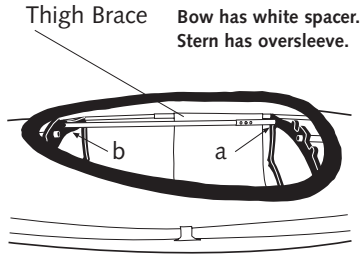

Thigh brace is secured with web strap.

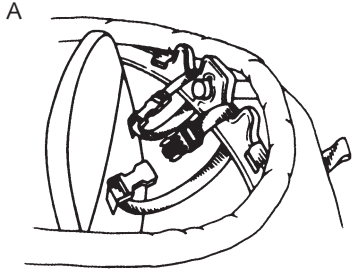

19 INSTALLING SEAT.

- Webbing at top of seat goes through crossrib, over top, connecting to buckle.
- Webbing at front of seat reaches the large crossrib and attaches around the side of the crossrib. Connect to ladderlock to fasten.
- Note: Webbing goes above chine bar.

20 INFLATE SPONSONS.

- Turn the top of the valve to open. When inflating sponsons, alternate sides to ensure the frame remains centered. The air pressure from the sponsons can shift the frame within the skin. Keep blowing until the skin is nice and tight. Twist top cap to close. Tuck sponson tubes and valves out of the cockpit area. Avoid stepping on the hose and valve, and try to keep the valve free of sand.

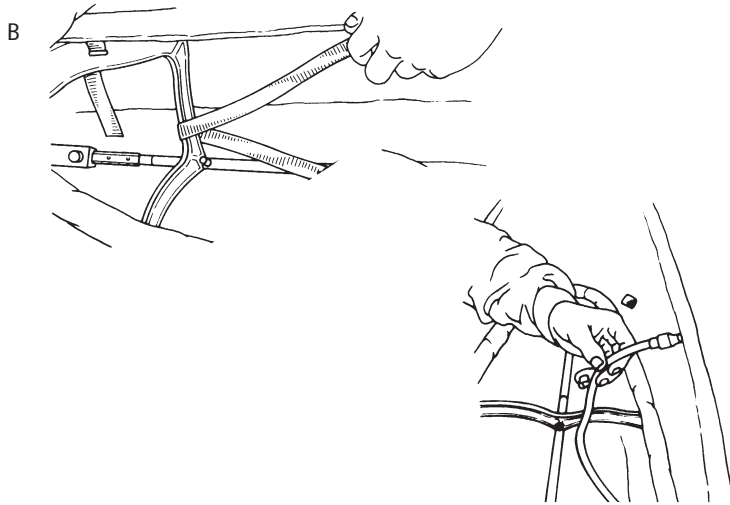

The Feathercraft Sea Sock

Made from high-quality coated nylon, the sea sock is a great safety item. The top of the sock fits tightly around the cockpit coaming rim. Contoured to fit along the seatback and bottom, the “foot” is loose through the cockpit, creating a “pod”. The paddler then sits in the sock. Legs and feet are not constricted. The spray skirt fits as usual. In the event of a capsize, water will only enter the sock, and not the whole boat. It's also great for keeping the inside of your kayak clean.

Tips on Usage and Installation

- The shiny side of the fabric faces in towards the kayak frame.
- When facing the bow of the kayak, the Feathercraft label should be on the right side.
- The center seam on the up-side of the Sea Sock should be centered on the bow point of the coaming.
- Once the Sea Sock is in place, sit in the sock, and “burp” it by lifting the edges, releasing trapped air that causes the sock to billow up.

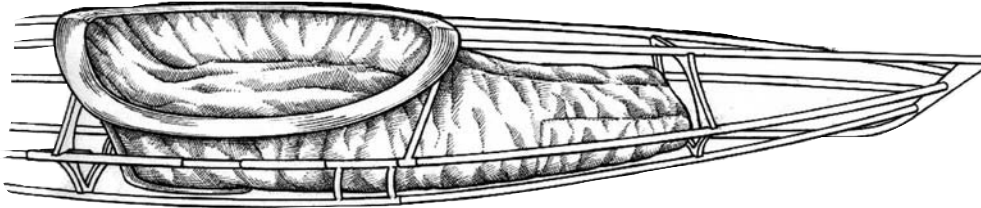

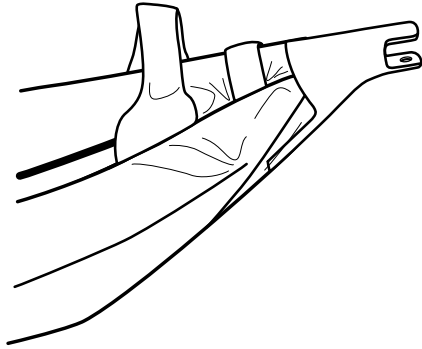

Installation of Optional Accessories

TO INSTALL THE OPTIONAL SURF RUDDER

The rudder bracket is permanently attached to the stern of the kayak.

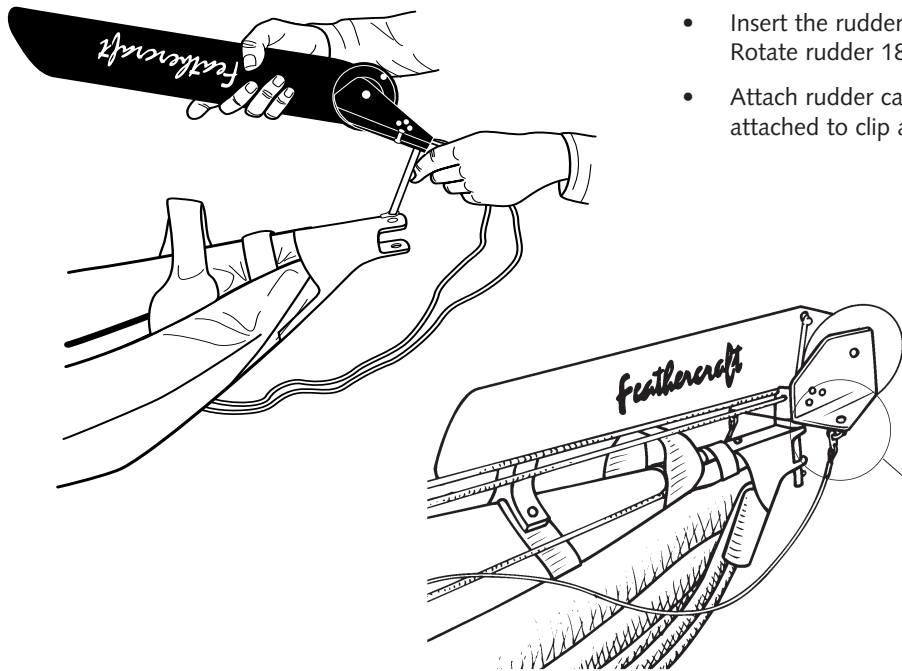

INSTALL RUDDER.

- Insert the rudder pin through the “key hole”. Rotate rudder 180°.
- Attach rudder cables with sister clips. White haulcord is attached to clip at the side of the cockpit.

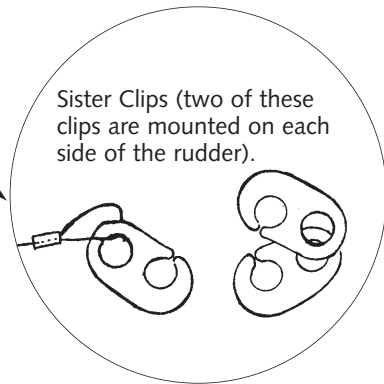

A CONNECTING RUDDER CONTROL TO FOOT BRACE

- Red webbing adjusters are connected to the foot brace. Unscrew thumb-knob on foot brace; stem of knob goes through grommet. To make the adjuster shorter, fold webbing over to second grommet. Re-attach knob to foot brace. Slide brace on to track. Ensure brace can slide easily on track. (If not, check knob that you re-attached.)

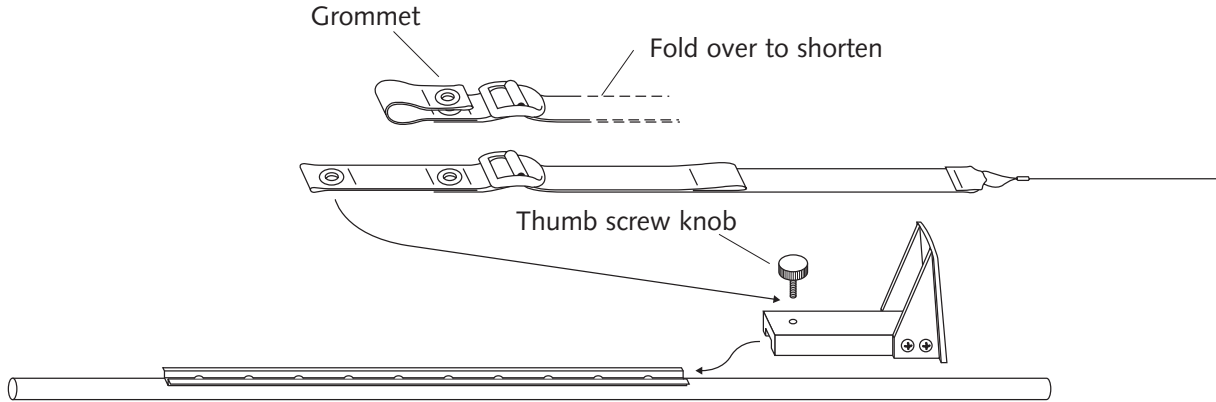

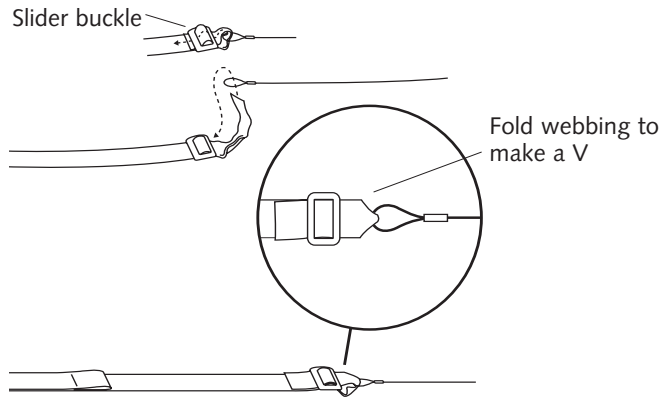

B CONNECT CABLE ADJUSTER TO STAINLESS STEEL CABLE.

- This is to attach the adjuster if you have installed the rudder from a kit.
- Slide end of webbing through slider buckle. Thread the webbing through the loop in the stainless steel rudder cable. Fold or “pinch” webbing to make a V. Re-thread webbing through slider buckle.

C CABLE LENGTH ADJUSTMENT

- To shorten cable length, pull on tab of webbing with loop; to lengthen, lift tab of ladder-lock buckle.

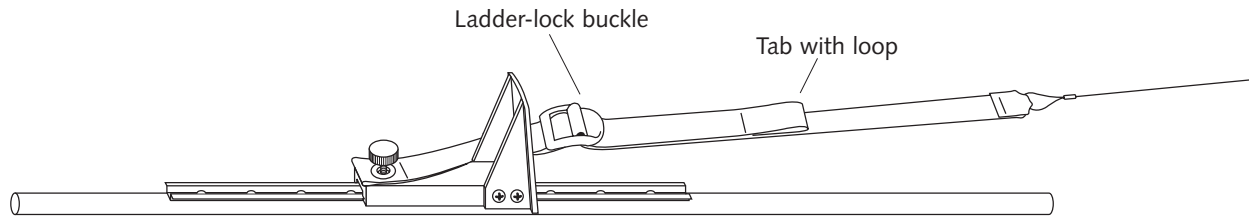

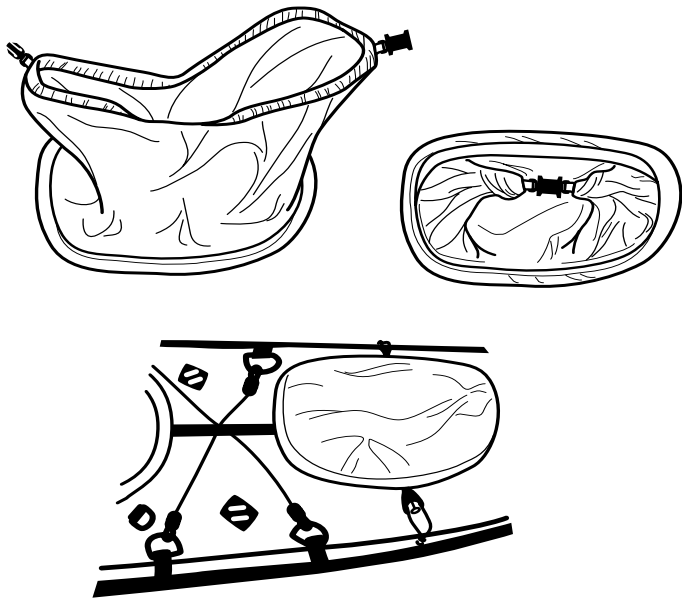

To install optional hatches

ATTACH HATCH RIMS.

- Attach hatch rims by folding the fabric sleeves sewn to the deck over the rim. Roll down inner closure and close with buckels. Place hatch cover over rim and secure with B-locks.
- During disassembly, don't forget to take the plastic rims off. Don't roll the skin up with the rims still in place.

© Feathercraft Products Limited 2007
Printed in Canada 11.2007
Recycled paper

