

YOUR ADVENTURE UNFOLDS

# Klondike

with built-in coaming

*Feathercraft*  
FOLDING KAYAKS <sup>TM</sup>

Feathercraft Products Ltd. 4-1244 Cartwright Street on Granville Island, Vancouver, British Columbia, Canada V6H 3R8  
Telephone: (604) 681-8437 Fax: (604) 681-7282 [www.Feathercraft.com](http://www.Feathercraft.com) [info@feathercraft.com](mailto:info@feathercraft.com)

# Contents

Klondike Folding Kayak.....	Page 2
Specifications .....	Page 3
Klondike Frame .....	Page 4
Care and Maintenance .....	Page 5
Klondike Assembly Instructions .....	Page 7
Disassembly .....	Page 37
The Feathercraft Sea Sock.....	Page 38

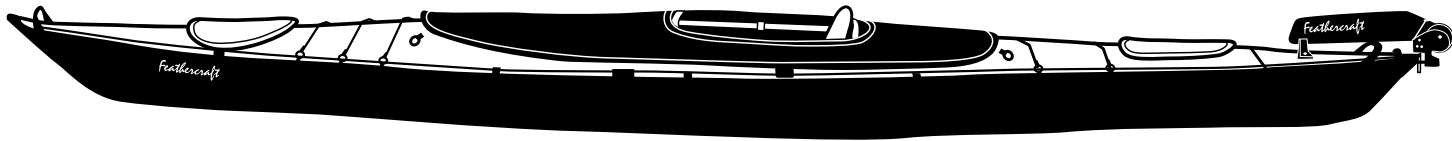

## The Klondike

The Klondike is our convertible double. With the open-cockpit design, seating can be changed to accommodate two paddlers, a solo paddler, or a small center seat for a child.

(Shown with optional solo spray deck.)

# Specifications

Length:	5.35m (17' 10")
Beam:	77.5cm (31")
Pack Size:	105 x 58 x 30cm (41 x 20 x 12")
Weight:	34.5 kg (76 lb)
Frame:	6061-T6 aluminum alloy
Crossribs:	High Density Polyethylene
Rivets and Spacers:	Aluminum and Nylon
Screws and Bolts:	Stainless Steel
Protective Coating:	Clear Anodized
Deck:	Polytech
Hull:	Duratek
Seats:	1/2" closed cell foam back & bottom, contoured plastic seat bottom, 3/16" plastic seat back with inflatable lumbar support, inside a 420 denier nylon seat cover.
Sponsons:	Welded Urethane, with hose and valve

## Standard Accessories

- Deck-lines and rigging
- Large-fin flip-up surf rudder
- Adjustable foot rests and seat slings
- Two nylon spray skirts
- Two-person spray deck
- Large duffel-style pack-bag, with shoulder straps and hip-belt
- Packcloth over-the-shoulder carrying bag
- Repair kit
- Assembly video

## Available Options

- Solo spray deck
- Triple spray deck
- Small child center-seat
- Small child spray skirt
- Sea Sock(s)
- Cockpit covers
- Sail Rig

# Klondike Frame

Crossribs are handcrafted from high density polyethylene

Chines, gunwales and deckbar permanently attached to keel plate (same for bow and stern)

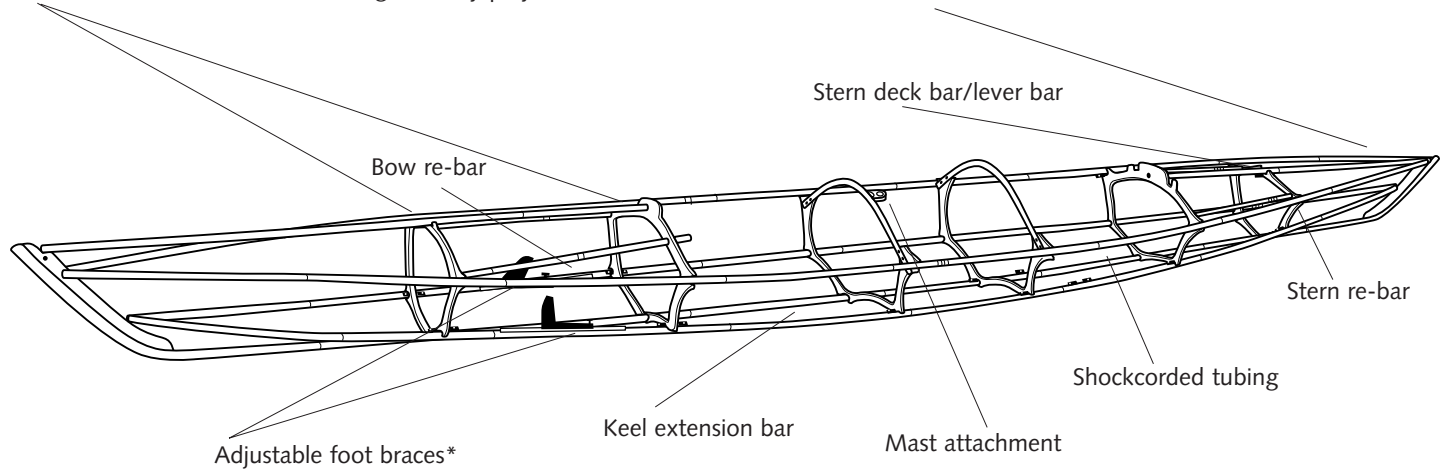

\* Stern foot braces are slings attached to rudder cable controls

# Care and Maintenance

## The Frame

The tubular frame is very strong and corrosion resistant. We recommend that the frame be disassembled after extensive use (2 – 3 months). The inside and outside of the tubes should be washed with fresh water. Try to keep the inserts and extension bars free of sand and grit.

Included in your repair kit is a small dropper tube of Bo-Shield T-9. This product is made by Boeing and is an excellent lubricant and protectant for aluminum.

Aerosol containers of Bo-Shield can be found at marine hardware stores. We also have available 4 oz bottles of Bo-Shield. However, please note, that the lid closure is not suitable for shipping after the bottle has been opened. This container would be good for your “at home” clean-up. We also have available Super Lube. This is a teflon lubricant in gel form. This product is also available from bike shops.

Apply the Bo-Shield lubricant to frame tube inserts, spring buttons and sliding pieces prior to assembly. If you should leave your boat assembled for a maximum of two months, this will assist in preventing tubes seizing.

Other maintenance “musts”:

- every two months completely disassemble the kayak.
- wash the frame completely with fresh water.
- reapply lubricant and/or wipe down tubes with Bo-Shield T-9.
- after paddling, sponge out the inside of the kayak. Do not allow water to pool along keel bar.
- The Extension Bars should be washed out with fresh water regularly. This ensures that they will slide easily and that the spring buttons will function properly. Be sure that these tubes are well lubricated when you assemble the kayak.

## The Skin

The surfaces of the skin will not rot. They are stable in sunlight and are very tear-resistant. Areas likely to be exposed to abrasion have been reinforced. However, we recommend care when approaching shore. Sharp rocks and barnacles can penetrate the skin. Never haul the boat over rocks.

The Polytech deck and Duratek hull are urethane. Seams are permanently sealed.

A patch kit is provided for deck, hull or sponson punctures. One urethane glue will work for repairs to all of these fabrics. Glue does have a shelf life and it should be fluid and not thick and gummy. We have replacement cans available. For quick field repairs, duct tape works very well and is a good addition to your repair kit.

## Sponsons

Due to the tight fit of the skin, the sponsons are under considerable pressure and some seepage of air may occur. It is advisable to periodically reinflate the sponsons. After paddling on hot days, release air from sponsons.

## To Repair/Replace Sponson

The sponsons can be completely removed from the sleeve sewn to the inside of the skin. Turn the skin inside out. The sponson chamber is open at bow and stern ends. Tie a long string through the hole in the tab at the end of sponson. Pull sponson through the center opening of the chamber (where sponson hose is attached). To reinstall, pull the cord attached to the new sponson back through the chamber. Ensure sponson is not twisted in the chamber. Repeat with the opposite side. Urethane glue and patches are included in the repair kit. Duct tape works well on the sponsons.

## Tie-Downs

Webbing straps across the stern will secure a spare paddle. Shockcord in front of the cockpit is handy for holding a chart. Loops which secure the perimeter line can be used for lashing additional gear to the deck.

## Packing the kayak in the bag

In the large duffel-bag, place the padded seats on the bottom. Lay crosspieces on top of the seats. The aluminum frame sections go in next. Tuck remaining small items (ie: hatch rims, rudder) into available space. The skin goes into the black packcloth bag.

## Carrying a loaded Kayak

Do not lift a loaded kayak from the ends. Do not pull or drag the boat using D-rings on deck. Handles at ends of kayak are for carrying. A webbing loop passed under the hull at the bow and stern ends and around the shoulders will make lifting easier when there are four people.

## Storage

Once clean and dry, the kayak can be stored assembled or disassembled in a shaded, dry place. When storing the kayak disassembled, take extension bars apart.



# Klondike Assembly Instructions

- If you have a VCR, and time permits, view the Klondike assembly video in its entirety before beginning assembly.
  - There may be small details that have changed from when the video was produced, to the production model of the Klondike. The written instructions are the most current to reference.
- 1 SET OUT FRAME PARTS AS SHOWN ON THE FOLLOWING PAGES.**
- Note: For ease of assembly, extension bars have been left attached to chine, gunwale and keel sections. When packing the kayak for storage, clean and lubricate tubes, and store extension bars disassembled.

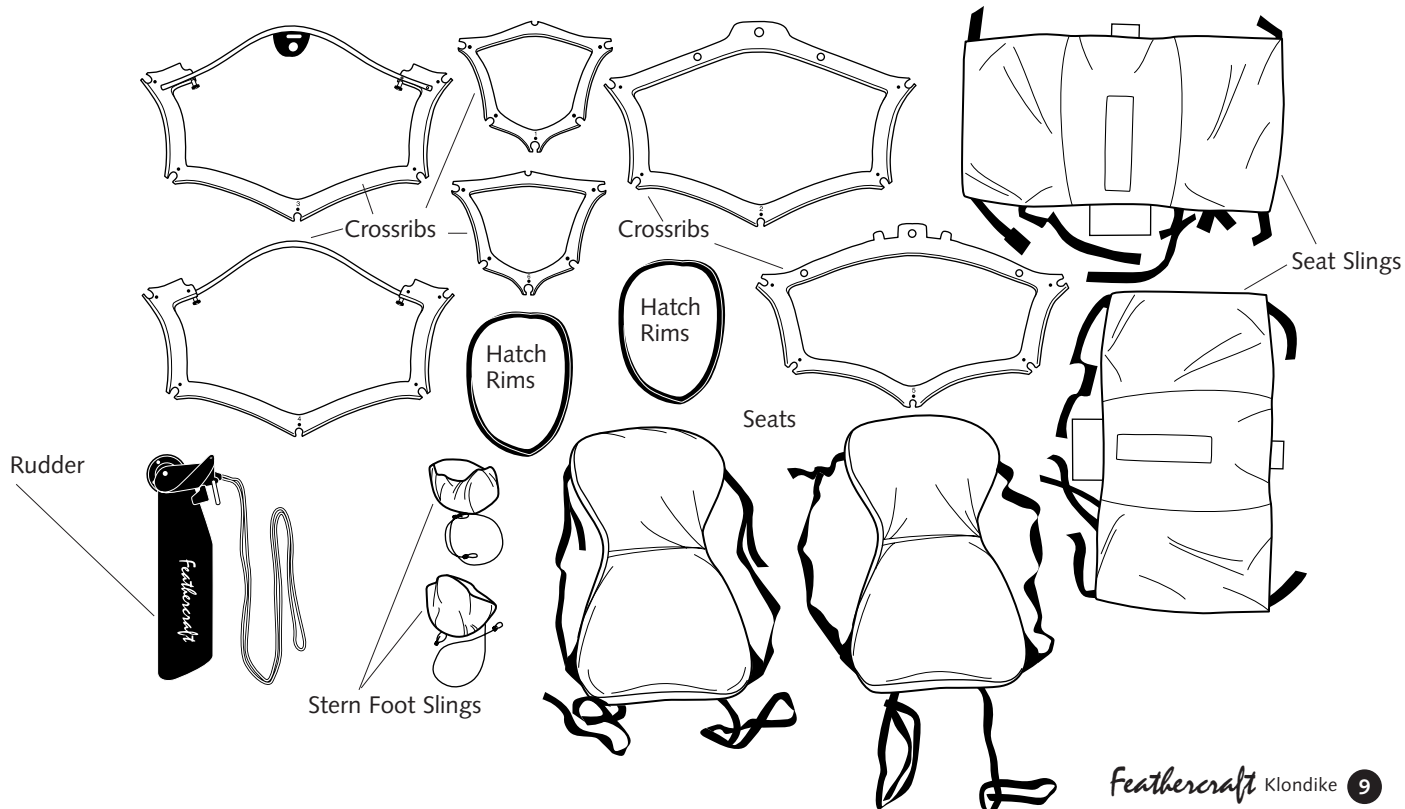

Stern deck bar/horizontal lever

Stern deck bar/vertical bar

Single Rebar Tubes

Stern Keel Bar

Extension Bars

Bow Section

Keel Bar with Mast Step

Bow Keel Bar

Stern Section

Rebar System



Stern Rim Inserts



Bow Rim Inserts

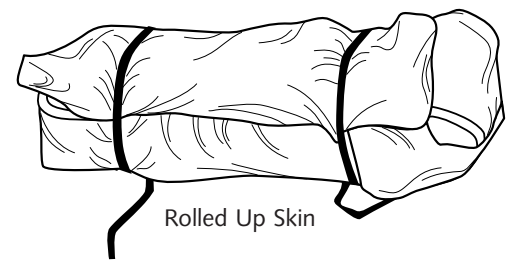

Rolled Up Skin

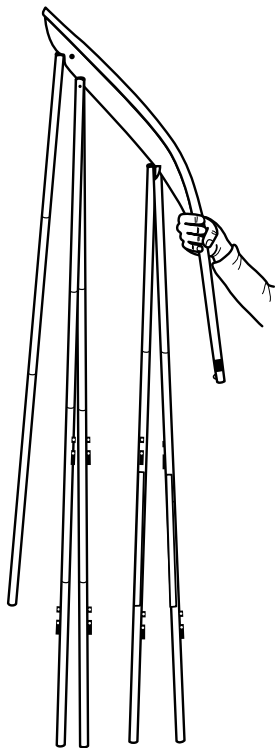

**2 "SHAKE OUT" BOW FRAME SECTION.**

(The bow section has foot track installed on chine bars.)

- Shock-corded tubes take shape.

**3 ATTACH TWO-SECTION BOW KEEL BAR**

(single black tape, hole for spring button).

- Slide on mid-connector sleeve (with no tape and mast step)
- To complete bow keel bar, slide on keel section with mast step.

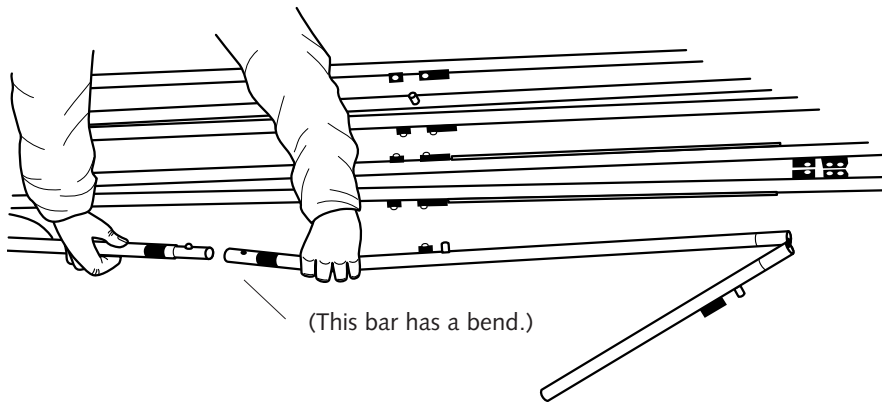

4 ATTACH FOOT BRACES TO TRACK ON CHINE BARS

- The bow paddler braces against foot vests fastened in position by the thumb screw knob. The foot plates can be reversed if more or less leg extension is required.

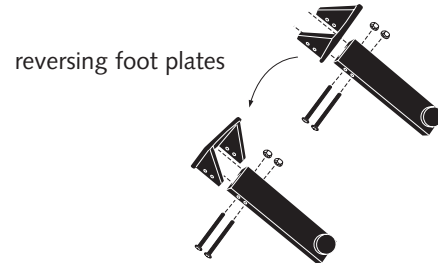
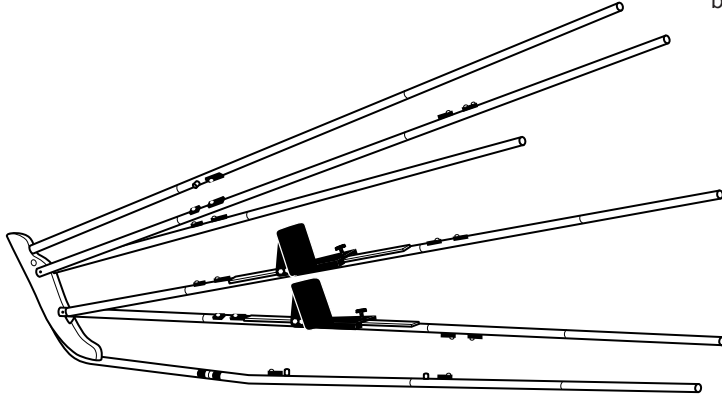

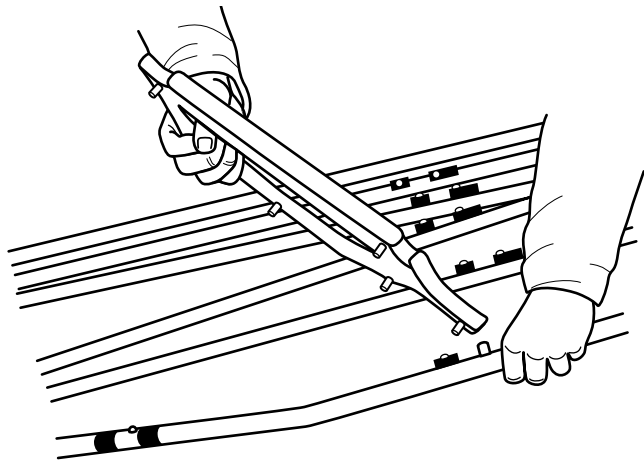

5 ATTACH #1 CROSSRIB.

- Pin on bottom of crossrib is inserted into hole in plastic block on keel tube.
- Chine and gunwale tubes are attached similarly, inserting pin into black block; then fastening into position by closing the "twister".

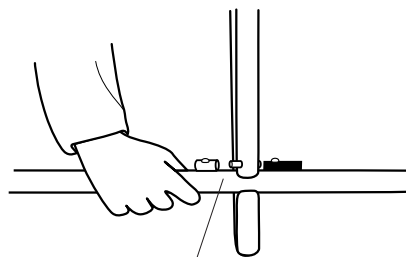

dog point screw to delrin block

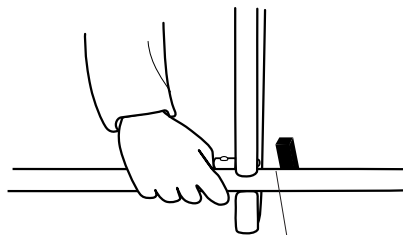

delrin block twister open

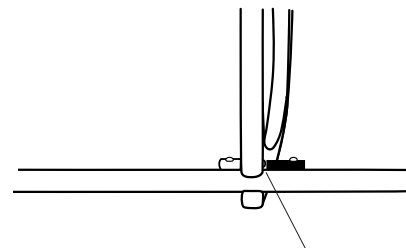

delrin block twister closed

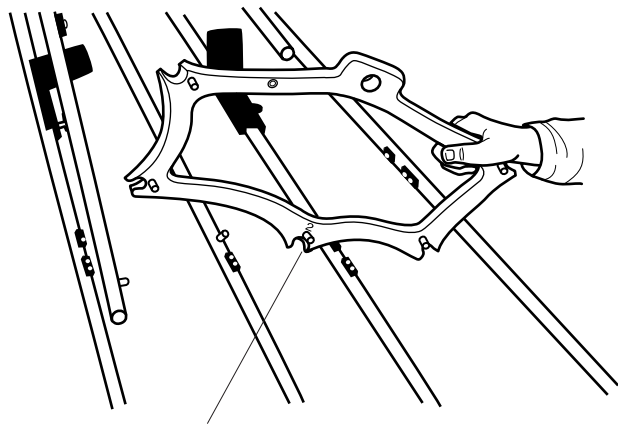

Screws are inserted to delrin blocks.

6 ATTACH #2 CROSSRIB.

- As you did with crossrib #1.

Turn bar to secure.

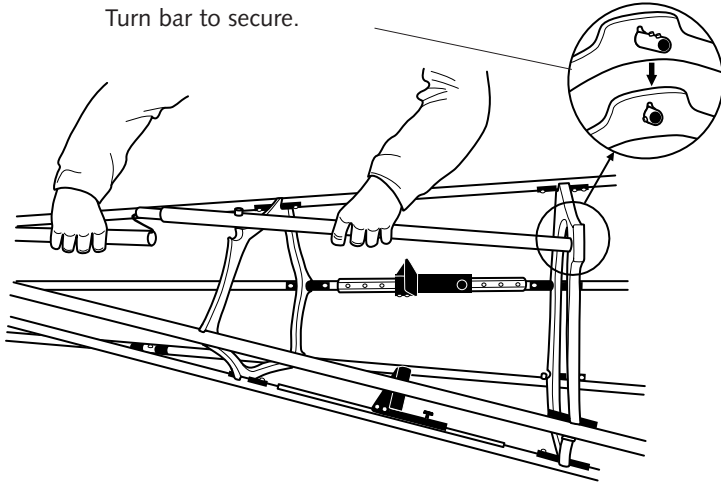

7 INSERT BOW DECK BAR.

- Tubes are shockcorded together. Pull section apart, insert through keyhole in top of #2 crossrib. Reconnect tubes. Turn tube so that spacers lock tube in place.

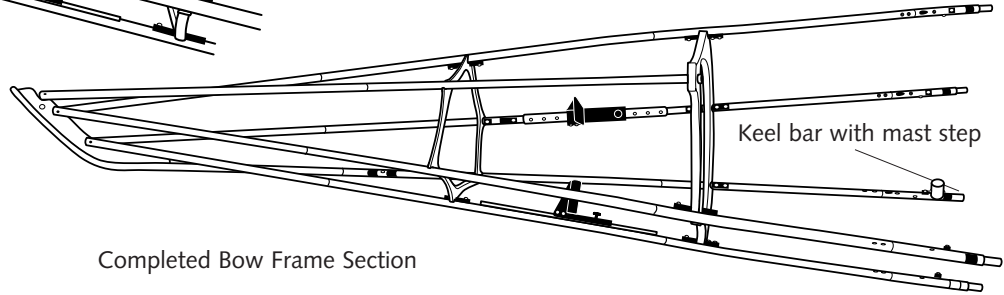

Completed Bow Frame Section



8 ASSEMBLE STERN SECTION.

- “Shake out” frame tubes. Attach three section stern keel bar (with double black tape).

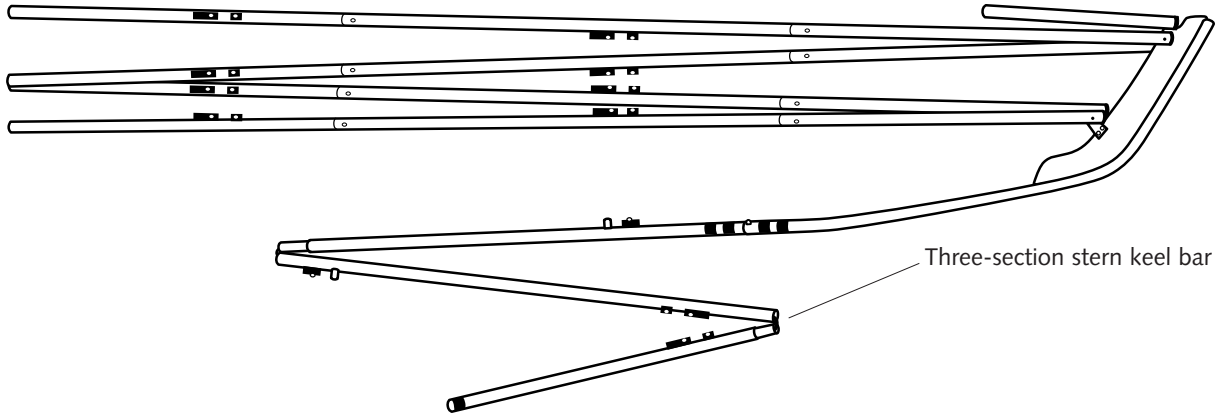

- 9 ATTACH #6 AND #5 CROSSRIB AS YOU DID THE #1 AND #2 CROSSRIBS.

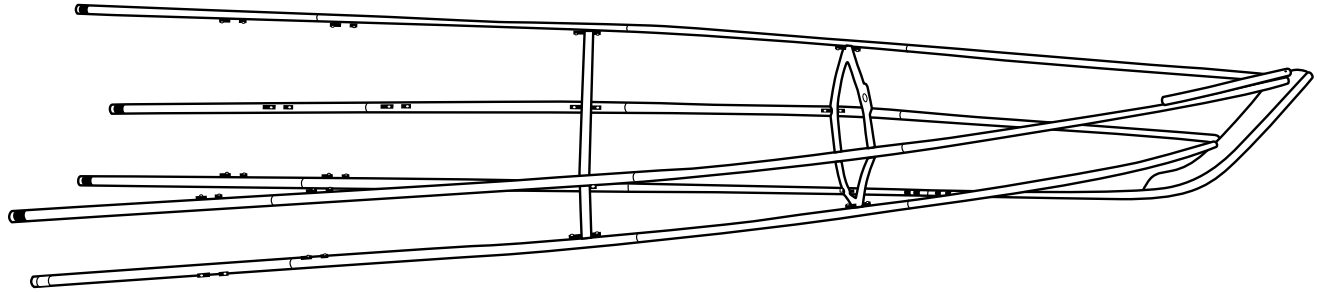

#### 10 ROLL OUT SKIN.

Note: rudder bracket is permanently attached to the stern end of the kayak skin.

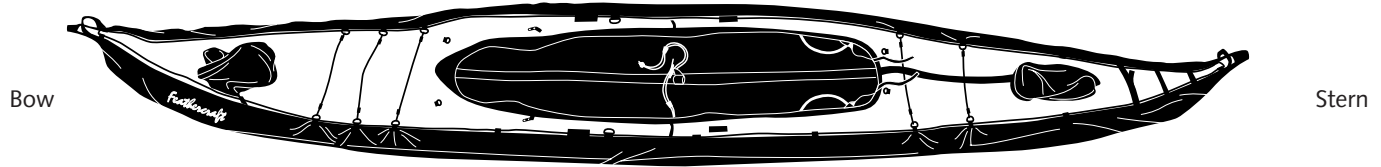

Note: During additional assembly steps, re-check that the frame has remained centered in the skin.

- The bow end has the Feathercraft logo.
- Have the velcro tab closures on the inside of the hull "open" before sliding the frame sections into the skin.
- Slide completed bow and stern frame sections into skin.
- Center the keel bar along the keel strip of the skin.
- Once frame is centered into skin, wrap velcro tabs around keel tubes.

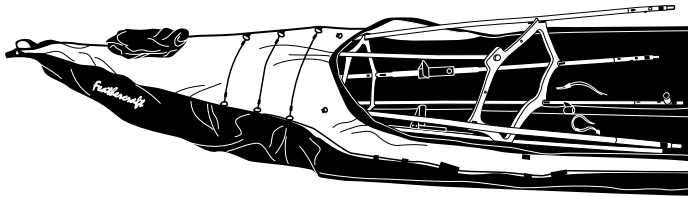

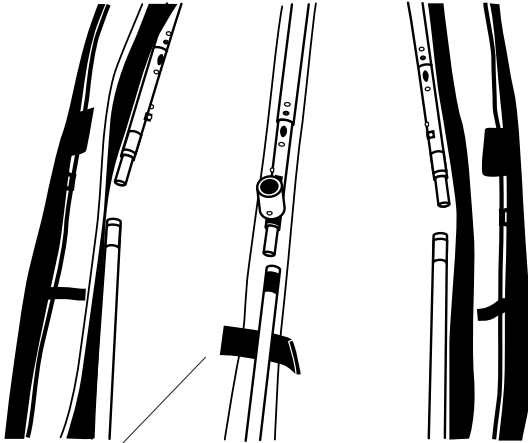

Open Velcro Tabs. Once frame is centered, close tab.

11 SLIDE BOW AND STERN KEEL BARS TOGETHER.

- Extension sleeve has black tape.

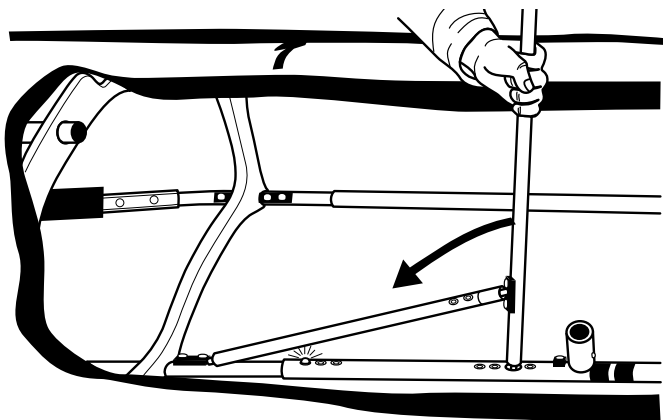

(Keel bar extension shown.)

**12 ATTACH CHINE AND GUNWALE TUBES TOGETHER, MATCHING COLORED TAPE.**

- Remember, it is easier to slide tubes together when they are in line. Pull tubes towards center of kayak and slide together.
- Ensure all joints are closed (no gaps between tubes).
- It is also easier to work on the opposite side of the framework from you.

**13 EXTENDING FRAME.**

- The horizontal and vertical lever bars (deck bars) are used to extend the frame.
- Extend the Chine bars. Spring button pops up into first hole.
- Extend keel bar until spring button appears in first hole.
- Extend Gunwale bars to first hole.
- Return to Keel. Depress spring button and extend to second hole.
- Then extend each Chine and Gunwale bar to second hole.

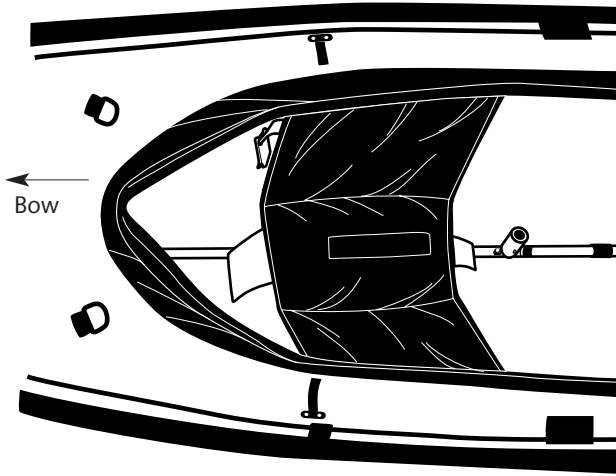

14 INSTALL SEAT SLINGS. THIS IS FOR THE DOUBLE CONFIGURATION.

**Note the stitching on the sling.** The wider section faces the bow; narrow section towards the stern. Wide velcro strip faces up. (Tags also indicate bow and stern.)

- Slide the upper flap of the sling (with buckles) over gunwale bar (upper most round tube). Click buckles together.
- Slide lower flap around chine bar (lower round tube). Connect with last flap, securing with velcro.

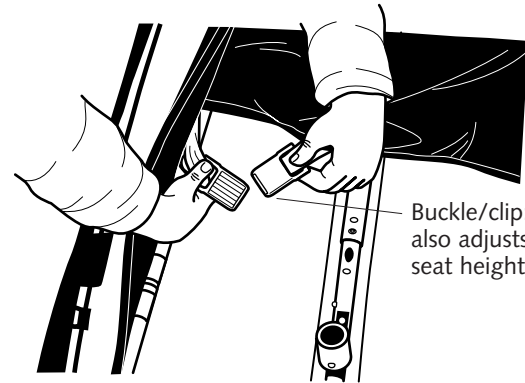

(For single configuration, the bow seat and sling will be positioned between the #3 and #4 crossribs.)

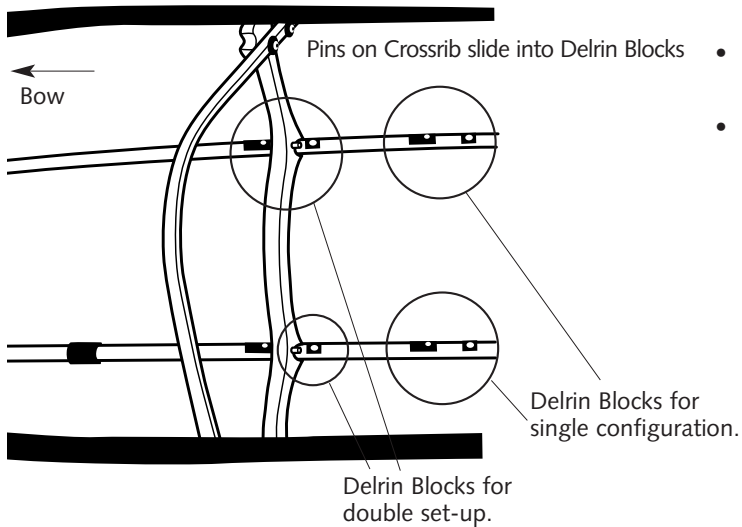

15 INSTALL #4 CROSSRIB.

- Pins on crossrib slide into black delrin blocks. Close twisters to secure.
- For double configuration, crossrib is installed in set of blocks closer to bow.
- For single configuration, crossrib is installed in second set of blocks.

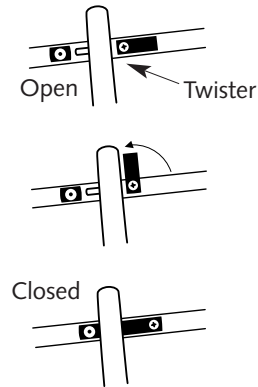

Note: When paddling in the solo configuration, a cord extension will be required to add to the rudder cable adjuster line.

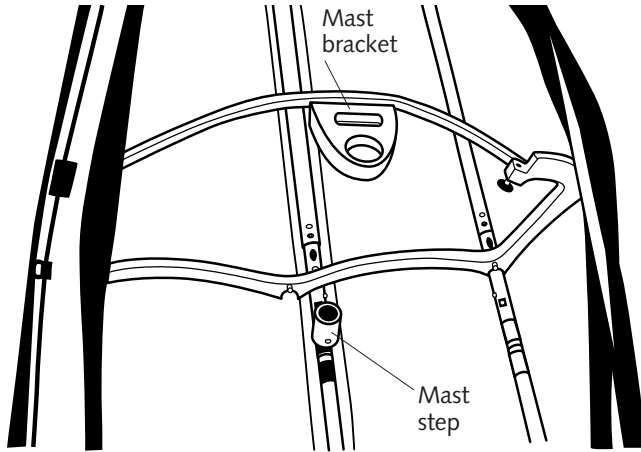

**16 INSTALL #3 CROSSRIB.**

- This has mast bracket attached.
- Line up crossrib so that pins are positioned to insert into black delrin blocks.
- Depress spring buttons; slide crossrib toward block, inserting pin.



17 INSERT STERN DECK BAR (HORIZONTAL LEVER) THROUGH HATCH

- Connect to deck bar tube attached to stern frame section.

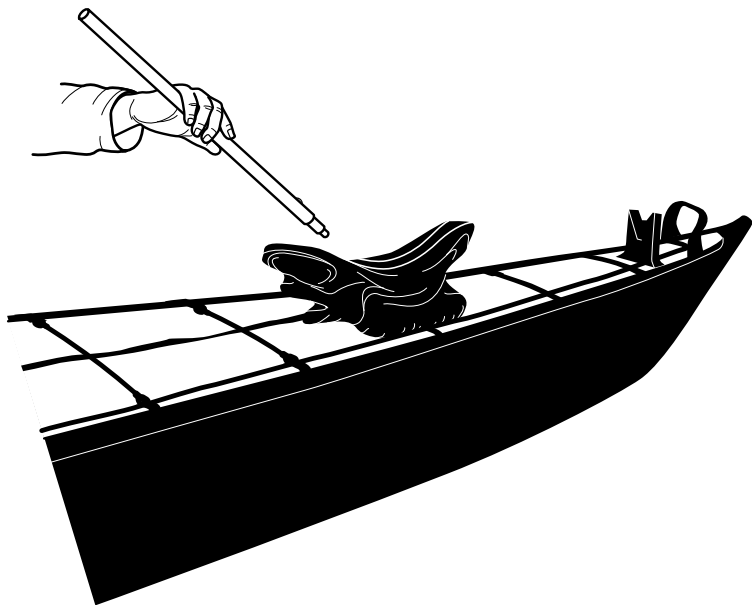

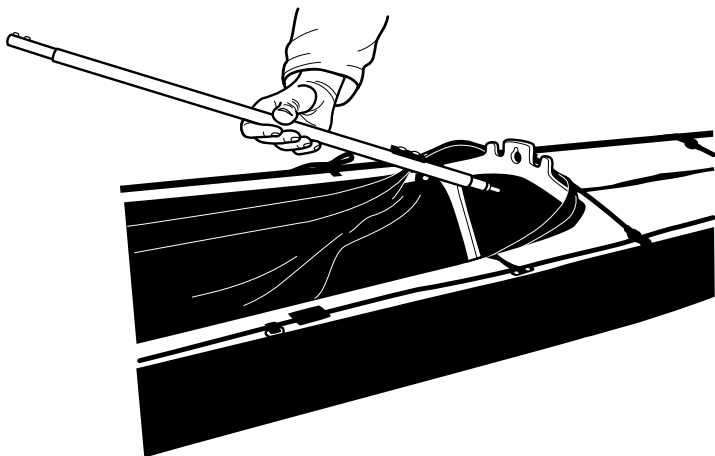

**18 INSERT STERN DECK (VERTICAL LEVER).**

- Go through center of crossrib, having end with stainless steel pin towards stern. Bring small end of deck bar through hole at top of #5 crossrib.
- Connect with deck bar/horizontal lever.
- Screw down coaming knob; bolt extends through hole in deckbar.

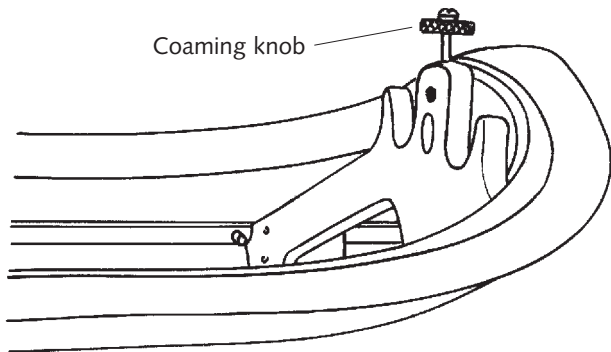

21 SLIDE RIM INSERTS INTO POCKET ON UNDERSIDE OF COAMING RIM

- S insert in pocket at stern
- B insert in pocket at mid cockpit

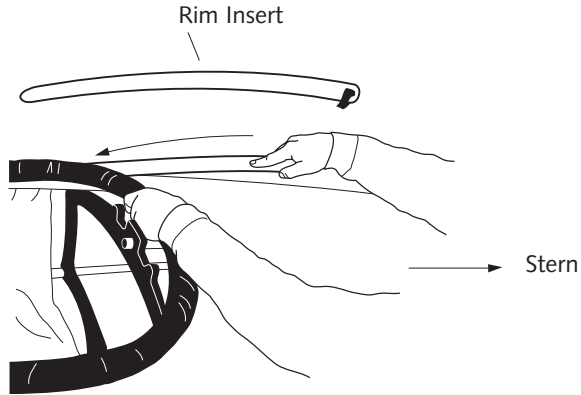

Slide into pocket on underside  
of coaming rim

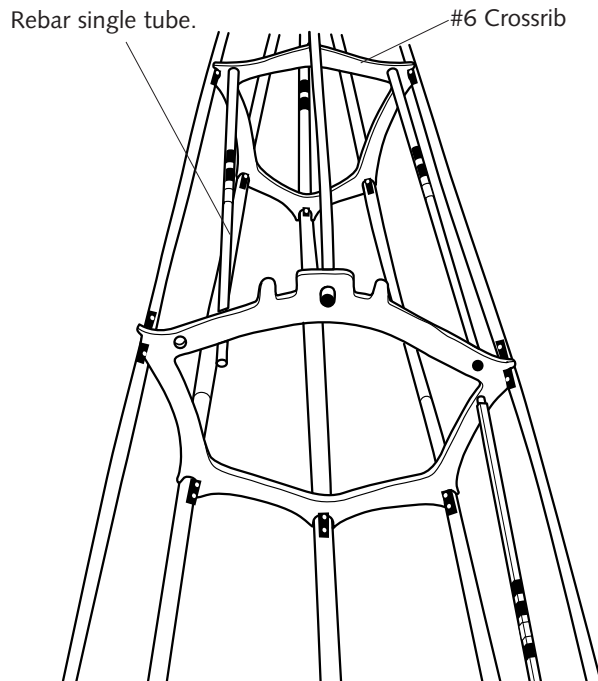

(Step is shown without skin.)

## 22 INSTALLING REBAR TUBES

### A) INSTALL STERN REBAR TUBES.

- Install two single tubes with three strips colored tape, one strip white tape. Red is port (left); green is starboard (right).  
Note: white band of tape always faces front of boat.
- The end of the single tube with the smaller tube insert, is inserted into the hole in the #6 crossrib.

### B) INSTALL BOW REBAR TUBES.

- Install single tubes with two strips of tape between #1 and #2 crossrib.

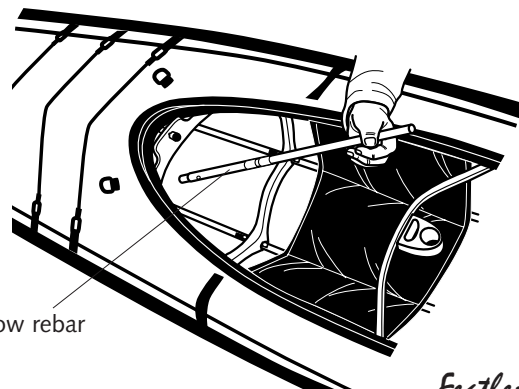

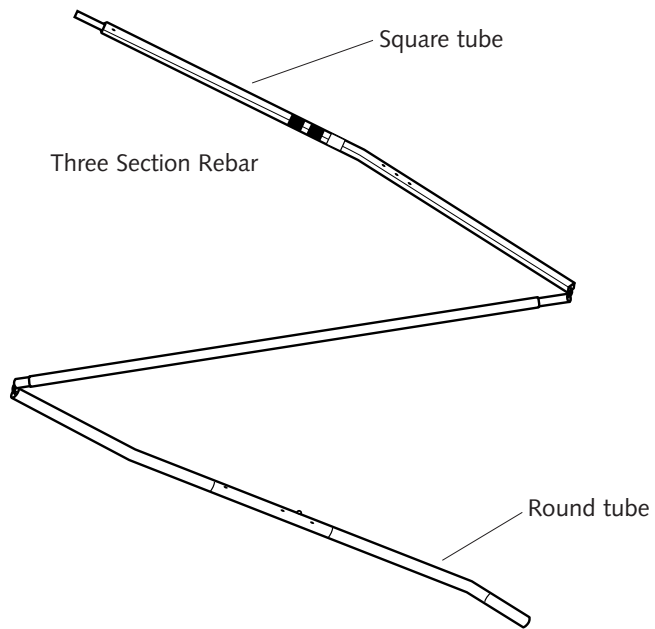

**23 ATTACH THE THREE SECTION REBAR.**

- The end with the square tube is towards the stern.

Stern

Square bent tube

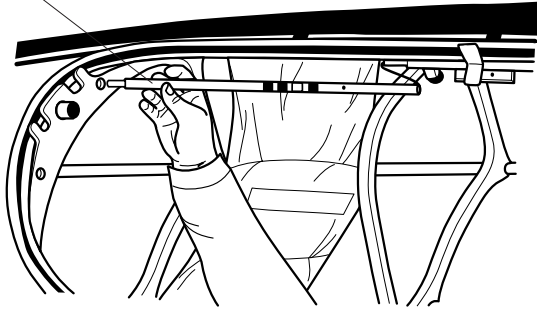

**23 ATTACH THE THREE SECTION REBAR. (CONTINUED)**

- Have rebar in “folded” position.
- Begin at stern end with square tube.
- Rebar connects through the hole in the #5 crossrib to the single tube you installed in Step #22.

Note: Rivets on square tube face down.

- Fold out rebar.

Bow

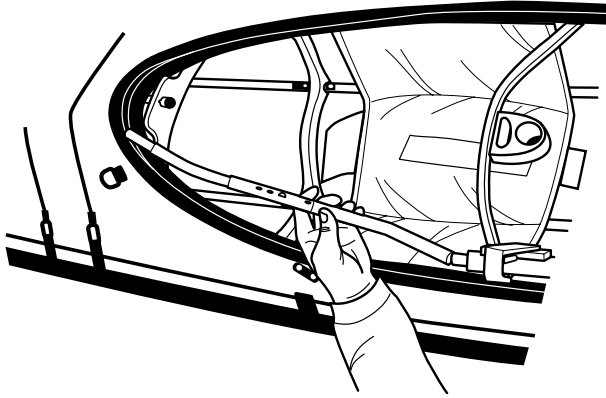

**23 ATTACH THE THREE SECTION REBAR. (CONTINUED)**

- Slide sleeve on bent tube forward, through hole in #2 crossrib, to attach to single tube. Spring button should end up in second hole.

**24 COMPLETE REBAR ATTACHMENT**

- On each side of the #3 and #4 crossribs.
  - (1) Turn flat bar into slot at edge of coaming rim
  - (2) Tighten thumbscrew knob at top edge of crossrib, attaching through rebar
  - (3) Secure web strap around rebar.

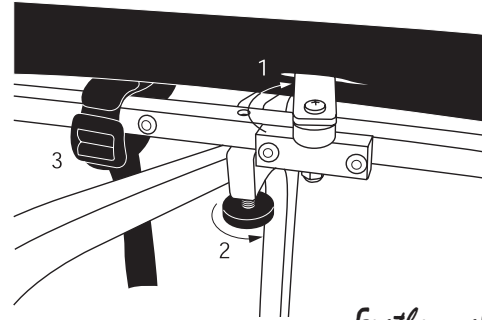

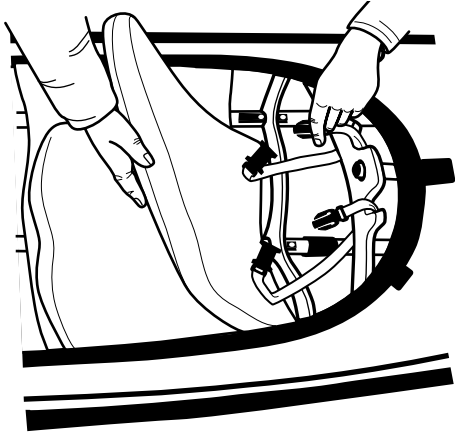

**24 INSTALL STERN SEAT.**

- Loop webbing with buckle around top of crossrib, through divet in crossrib.

**25 INSTALL BOW SEAT.**

Loop webbing around #3 crossrib.

Webbing attached to front of the seats is looped around bottom of crossrib in front of the seat. (Same for both bow and stern seat.)

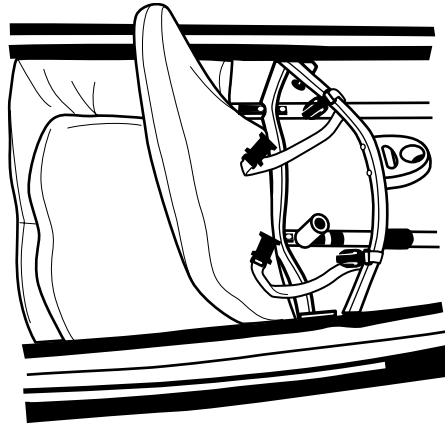



26 ATTACH RUDDER CONTROLS/STERN FOOT SLINGS.

- The foot slings are attached to the stainless steel rudder cable.
- Pull the length of shockcord attached to the base of the sling forward and wrap the cord around the #2 crossrib.
- To shorten cable length, pull on tab of webbing with loop; to lengthen, lift tab of ladder-lock buckle.

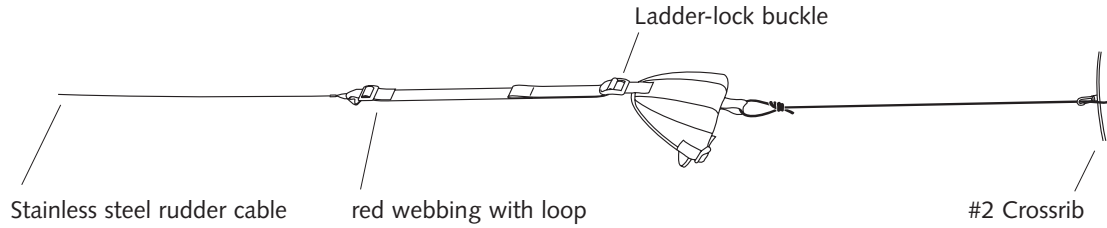

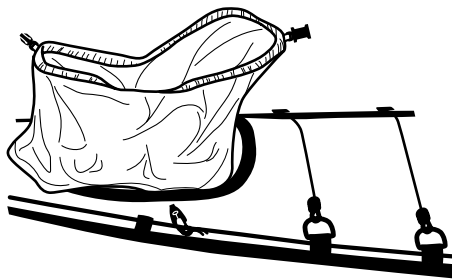

27 INSTALL HATCH RIMS.

- Place plastic rim over hatch opening. Wrap fabric sleeve with bungee over rim.
- Fold down hatch neck. Close with buckle.
- Cover with hatch cover. Secure with toggle.

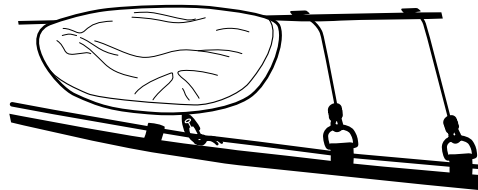
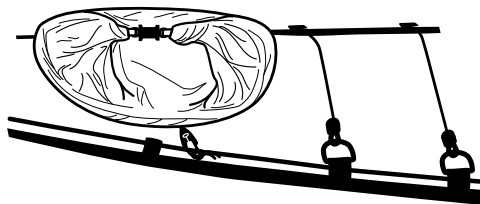

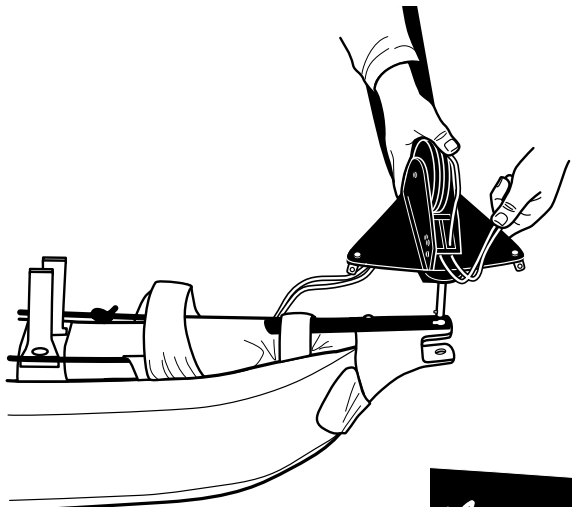

**28 INSTALL RUDDER.**

- Insert pin through keyhole in rudder casting. Rotate rudder into position.
- Attach stainless steel rudder cable to sister clips on rudder delta.

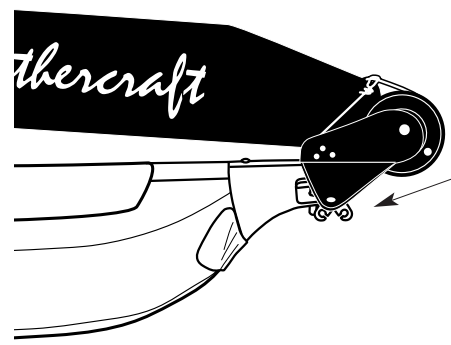

**Sister Clips (two of these clips are mounted on each side of the rudder).**

28 INSTALL RUDDER. CONTINUED

- Attach stainless steel rudder cable to sister clips on rudder delta.
- White rudder haul cord runs up towards side of the cockpit. Connect to plastic hook.

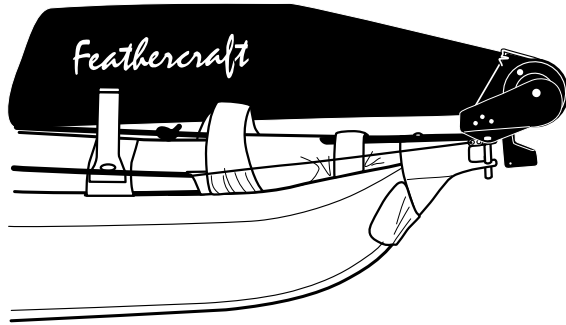

29 INFLATE SPONSONS.

- Turn the top of the valve to open. When inflating sponsons, alternate sides to ensure the frame and skin remain centered. The air pressure from the sponsons can shift the frame within the skin. Keep blowing until the skin is nice and tight. Twist top cap to close. Tuck sponson tubes and valves out of the cockpit area. Avoid stepping on the hose and valve, and try to keep the valve free of sand.

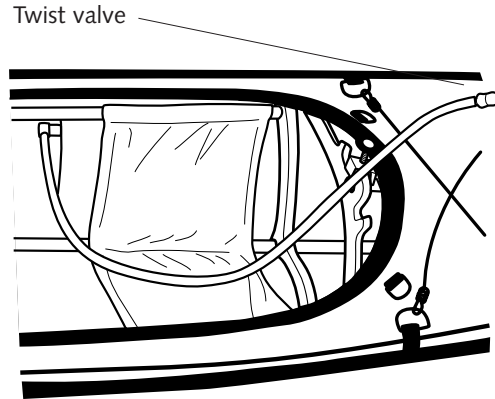

**30 TO SECURE SPRAY DECK:**

- Loop bow edge of spray deck around bow of coaming lip.
- Stretch back to stern.
- Tuck shockcord edges under coaming lip matching up velcro sections.
- Spray skirts work as usual, fitting around rims sewn into spray deck.

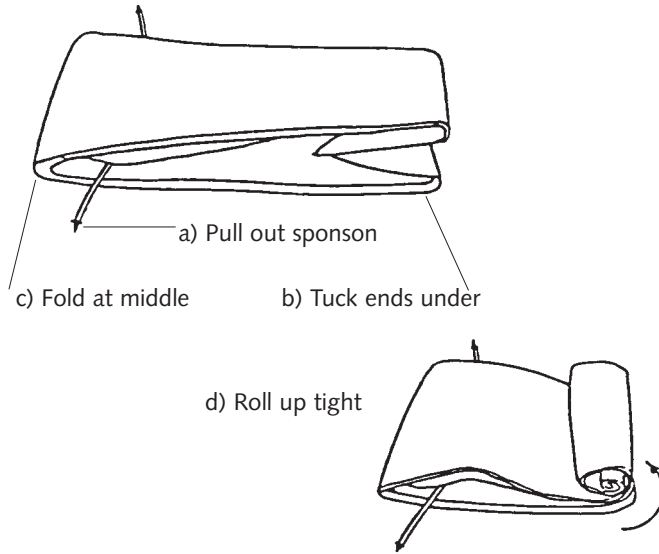

## Disassembly and repacking the pack

Let the air out of the sponsons. Remove rim inserts and hatch rims. Remove seats. Follow the rest of the assembly instructions in reverse. See tips for packing the bag on page 8 "Care and Maintenance".

### TO FOLD THE SKIN UP TO THE MOST COMPACT ROLL:

- a) have the sponson valves open, and pull the sponson hoses out to the side of the skin
  - remember to remove the plastic hatch rims.
- b) fold the ends into the center; twist them so they lay flat
- c) fold in half
- d) begin rolling the skin at the open-fold-edge; roll it up like you would a thermarest, kneeling on the roll as you go
  - close sponson valves; tuck these into the folded skin
  - cinch the roll with the webbing ties

## The Feathercraft Sea Sock

Made from high-quality coated nylon, the sea sock is a great safety item. The top of the sock fits tightly around the cockpit coaming rim. Contoured to fit along the seatback and bottom, the “foot” is loose through the cockpit, creating a “pod”. The paddler then sits in the sock. Legs and feet are not constricted. The spray skirt fits as usual. In the event of a capsize, water will only enter the sock, and not the whole boat. It's also great for keeping the inside of your kayak clean.

### Tips on Usage and Installation

- The shiny side of the fabric faces in towards the kayak frame.
- When facing the bow of the kayak, the Feathercraft label should be on the right side.
- The center seam on the up-side of the Sea Sock should be centered on the bow point of the coaming.
- Once the Sea Sock is in place, sit in the sock, and “burp” it by lifting the edges, releasing trapped air that causes the sock to billow up.

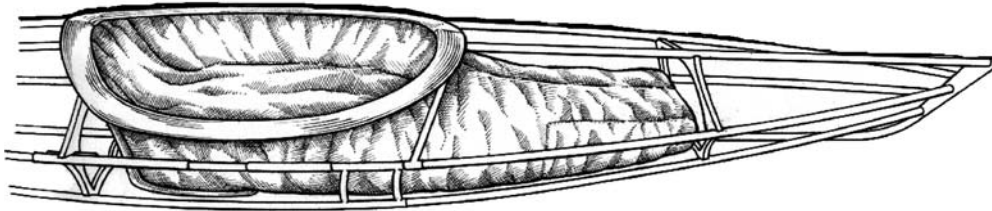

**TO DETACH FOOT SLINGS FOR USE INSIDE OF THE OPTIONAL STERN SEA SOCK**

- The sea sock for the Klondike can only be used in conjunction with the spray deck.
- Detach shockcord from #2 crossrib.
- a) Detach red webbing from stainless steel rudder cable.

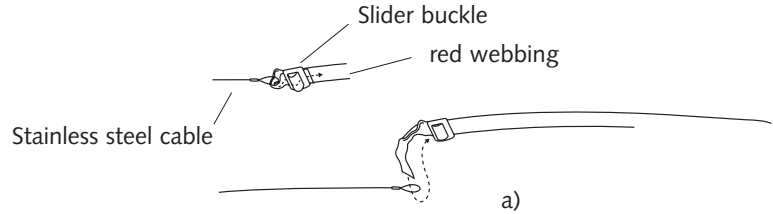



- b Thread the red webbing (that you removed from the stainless steel cable) through the small black webbing loop sewn to the inside of the sea sock.
  - Re-thread the red webbing through the slider buckle.
  
- c Brass snaps are attached to the inside of the foot of the sock.
  - Attach the foot sling to the brass snap, at the loop where the length of shockcord on the sling is connected.
  - The stainless steel rudder cable is attached to the brass snap on the outside of the sea sock.
  - The length of shockcord attached to the foot of the outside of the sock is pulled forward and wrapped around crossrib #2.
  - Fit the top of the sock around the coaming rim in the spray deck.

#### CABLE LENGTH ADJUSTMENT

Be seated in the sock with feet in foot slings.  
 To shorten cable length, pull on tab of webbing with loop.  
 To lengthen, lift tab of ladder-lock buckle.

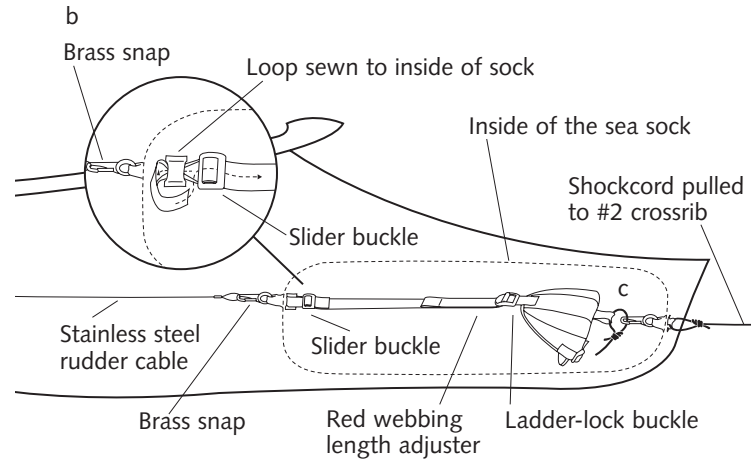

© Feathercraft Products Limited 2005  
Printed in Canada 6.2005  
Recycled paper

